

R N I B

See differently



Building Sight

Design principles and practical recommendations
for accessible buildings and environments

Peter Barker | Jon Barrick | Rod Wilson | Carol Thomas | Caroline Lewis

Peter Barker | Jon Barrick | Rod Wilson

Building Sight

Design principles and practical recommendations
for accessible buildings and environments

Updated in 2023 by Caroline Lewis and Carol Thomas,
Access Design Solutions UK
First published 1995

London : HMSO
in association with the Royal National Institute of Blind People

Contents

- 5 Introduction
- 8 **Design Principles**
- 9 Section One – Design Principles
- 11 Inclusive design
- 15 The nature of sight loss
- 24 **Design Practicalities**
- 25 Section Two – Design Practicalities
- 27 Site, Street and Surroundings
- 39 External Design
- 45 Lighting
- 59 Interior Decoration
- 67 Signs and Notices
- 75 Using other senses
- 81 Building Services
- 91 Building Management
- 95 Dedication



Introduction

“Many barriers are put in the path of people with sight loss – our task is to dismantle them.”

RNIB exists to challenge society to see sight loss differently. We seek to do this in two ways:

- By providing services that help blind and partially sighted people to determine the quality of their own lives;
- By questioning society's assumptions – and therefore its attitudes, behaviour and actions – concerning people with sight loss.

Sight loss operates on many levels. Personal difficulties may be overcome – or at least minimised – with the type of help that RNIB offers. However, barriers arising from uninformed attitudes and a lack of sympathy often pose more challenging problems. These can only be solved through a process of education and information.

Over the past few decades there has emerged a growing awareness that good design – whether of buildings, interiors or products – should by nature

be inclusive. Of course, it would be impossible to design any environment to the exact specifications of every minority group, each with its own individual demands. However, it is perfectly possible to create environments that embrace and invite the widest possible range of users. Not only this, when you design for anyone it is better for everyone. If you are creating inclusive environments for people with sight loss, you can also benefit many others.

For example, improved wayfinding around a building is better for everyone; Reducing sensory overload features, such as highly patterned surfaces, is helpful for people with sight loss; it also mitigates against the negative effects on people who are neurodivergent.

RNIB's initiatives Visibly Better Living and Visibly Better Spaces incorporate this “design for anyone, better for everyone” principle. Both these Visibly Better programmes support members in creating inclusive design – as detailed

within this publication. Please go online for further information: rnib.in/VisBetterBuildingDesign

Inclusive design will often depend upon the underlying attitudes and decisions of planners and developers, so we hope that the messages in this handbook will also reach those decision-makers who have the power to encourage the work of enlightened architects and designers. We also hope it reaches those who can stop inaccessible environments being created.

Too often a token planning gesture towards disabled people seems to add cynicism to thoughtlessness: the ramp that provides wheelchair access to an un-negotiable building; the braille invitation into an environment that, once entered, proves positively hostile to people with sight loss. This said, much can be achieved by sensitive and informed design.

Most housing organisations, architects and building project managers now recognise that inclusive design not only enhances the quality of life for everyone who uses a building, but that it also says something about the cultural values of the supervising organisation.

This handbook is intended to help those responsible for shaping the environment in which we all live.

While recommending that the widest possible range of disabled people should always be taken into consideration, no apology is made for concentrating on the needs of people with sight loss. Other publications have dealt with the needs of physically and sensory impaired people, but there are very few books dealing directly with sight loss.

Meanwhile, the number of adults aged 18 and older who are blind or partially sighted in this country has been estimated at over two million. It's estimated that 27 per cent of those between 75 – 84 are living with sight loss, a number that climbs to 32 per cent in citizens 85 and older. For those between 65 and 74, the figure is around 20 per cent. The number of older people will rise during the next 30 years, due to demographic changes now occurring in British society. The conclusion is inescapable: we must design for an older population, and therefore we must design for people with sight loss.

The number of older people will rise during the next 30 years, due to demographic changes now occurring in British society. The conclusion is inescapable: we must design for an older population, and therefore we must design for people with sight loss.

This publication reflects knowledge, expertise and experience gained by RNIB over a long history. We present this in two distinct sections. The first – Design Principles – examines the different types of sight loss which affect people’s relationship with the designed environment and explores the broader ethical and philosophical directions underlying our recommendations. The second – Design Practicalities – takes a closer look at problems and gives step-by-step advice on design specifics relating to the way in which people with sight loss negotiate different exterior and interior spaces.

It does not claim to be a final work on the subject – experience tells us that as circumstances change so must our responses – but it is certainly the most comprehensive work on this subject to date. It provides answers to many of the questions RNIB is regularly asked, while acknowledging that on some topics – particularly lighting – more research will have to be done before we can arrive at informed recommendations.

Most of the ideas in this handbook can be integrated into new building projects. Many can be economically incorporated into an existing building through routine maintenance or refurbishment. Opportunities must be taken, wherever they occur, to meet the needs of people with sight loss.

Every thinking designer of buildings and interiors will agree that architecture holds up a mirror to society. Just as the modern architecture of the early years of the last Century reflected a new-found fascination with technology and the machine, there is now an opportunity for contemporary building design to reflect the strong groundswell of social concern that exists for the interests of all members of society, including those physically, sensorily or cognitively impaired.

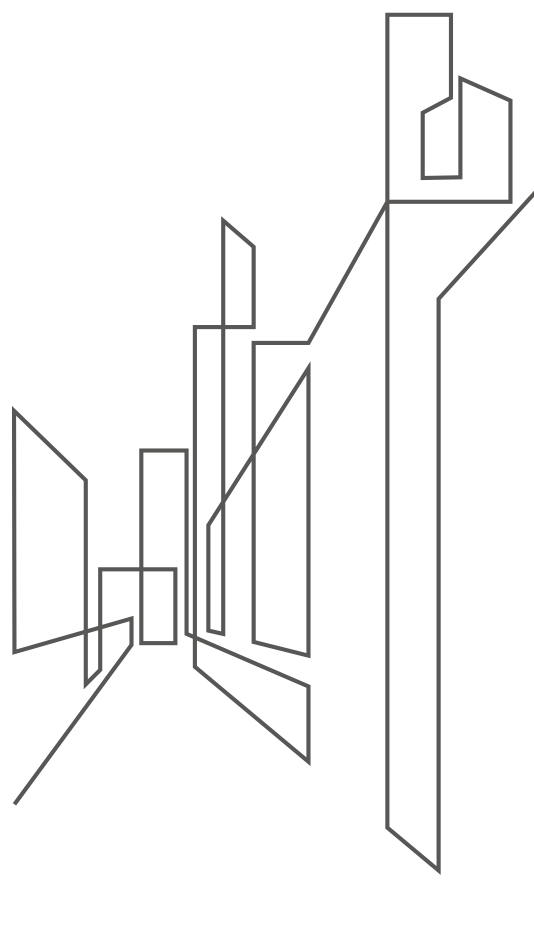

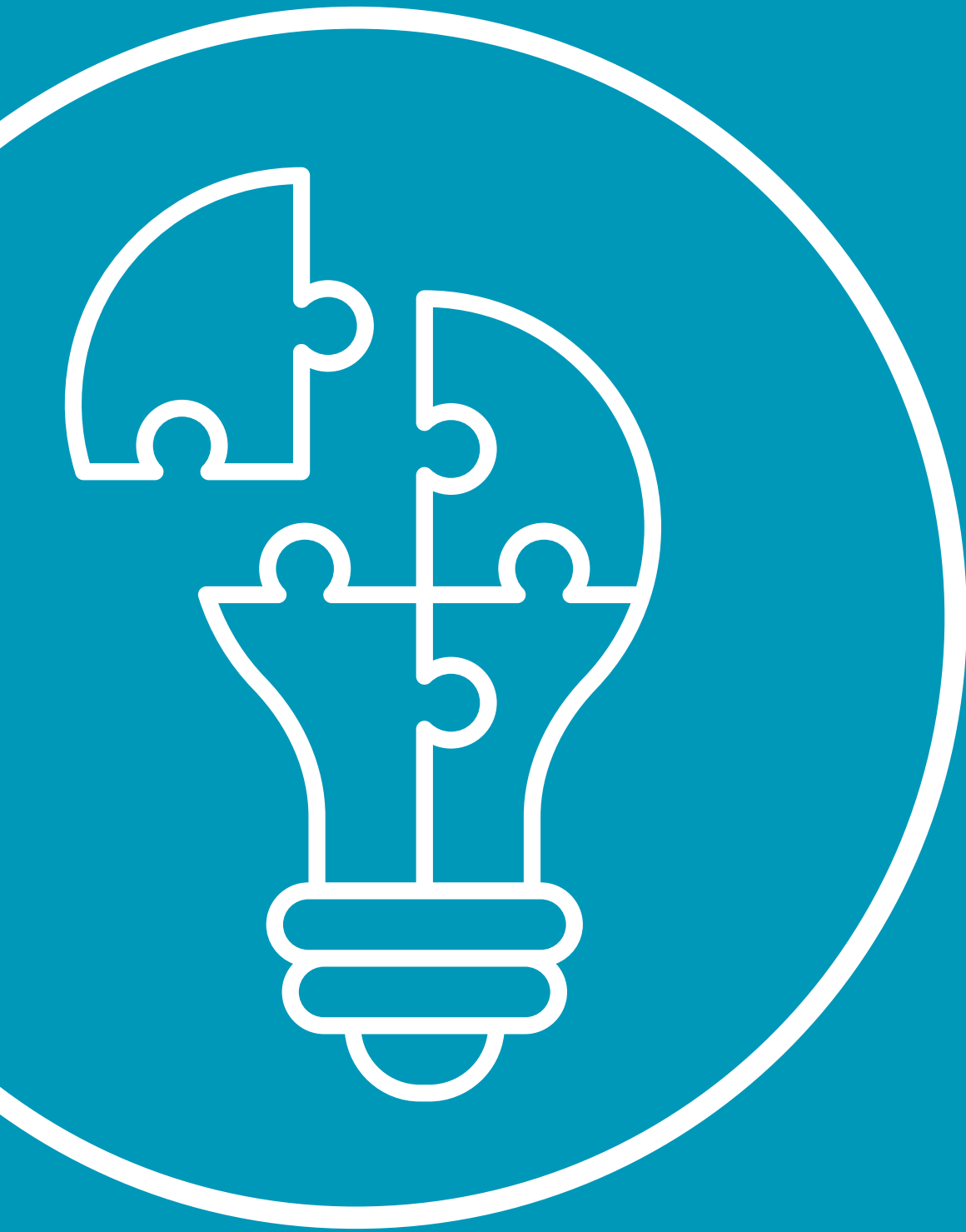

Design Principles

Section One – Design Principles

This section introduces the underlying ethical and philosophical arguments which shape the design suggestions in this handbook.

Each chapter explores the spatial and environmental implications of the different types of sight loss which people experience. Design principles are established to give a basis for practical recommendations.





Inclusive design





There is a certain type of design approach that sets out to include as many people as possible. It does not look for the lowest common denominator, nor does it attempt to reconcile the – sometimes conflicting – needs of every possible minority group in society. Rather, by considering many different varieties of requirements, inclusive design tries to break down unnecessary barriers and exclusions. In doing so it will often achieve surprising and superior design solutions that benefit everyone.

One of the objectives of this handbook is to offer recommendations concerning the requirements of the disabled population. More specifically, it is concerned with the requirements of people with sight loss. In addressing these requirements, designers, architects, planners and building managers will frequently improve the quality of the built environment for everyone.

Unfortunately, people are so accustomed to tolerating poor design, that it is only when relevant faculties are diminished that some design shortcomings stand fully revealed. The overall objective should be to design any building or environment in such a way that all people – including people with sight loss – can move around as independently and freely as

they would like. These fundamental issues need to be understood and incorporated from the very beginning of the design process.

Redefining “architecture for blind people”

The design recommendations in this book reflect that the great majority of people with sight loss are not totally blind but have varying degrees of limited vision which they use as an aid to mobility.

Research conducted into an “architecture for blind people” in the 1960s and 1970s focused on non – visual information. Vanoli [1] summarises:

“The ability of many blind people to orient and locate themselves by using non-visual spatial information has led many to the conclusion that a blind person would benefit from an environment that complements and assists the blind person in this process.”

This considers a non-visual spatial conception of the world in which environments could be designed to offer non-visual clues, using touch, sound, aroma and kinaesthetic information derived from wind motion against body movement to aid mobility.

[1] Vanoli, D.V. Unsighted Barriers. Unpublished diploma thesis, 1972



Mettler[2] comments on this process:

“Some sighted people exaggerate the extent to which blind people are sensitive to non-visual information, while others, lacking the skills to make substantial use of non-visual data, underestimate the potential value of this information.”

Mettler describes his experience of spatial location when vision is removed:

“Just as a sighted person explores the environment with the sensory apparatus available, so does a blind person, but in the latter case, primarily through tactile, auditory, olfactory and kinaesthetic information gathering (supplemented by any residual vision)... In time, I found that remembered visual information gradually diminished in significance.

My working conception of space was no longer built up by considering relative positions of material objects as they appeared in my visual field. Instead, it was built up by considering relative positions of material objects separated by distances revealed by movement as I detected varying tactile, auditory and olfactory data. I then determined how objects were arranged with respect to one another and my place among them. Familiar strategies for making visual

observations, passive by comparison, gave way to strategies requiring a greater level of active interaction with the environment.”

- The argument for environmental accessibility should be seen in the context of equal opportunities. The prejudices and stereotypes arising from ignorance have to be confronted, and this must be part of the ongoing work of all involved in the disability movement.

The barriers posed by inaccessible environments, inadequate mobility training and lack of information, curtail the opportunity of many people with sight loss even to leave their own home.

Research from RNIB shows that large numbers of people with sight loss appear isolated and trapped in their homes, with many dependent on sighted assistance for tasks such as shopping.



Any design change must be useful, practical, empowering or enabling, and the individual user is always the best judge of any building modification. Therefore, it is essential to listen to the comments of blind and partially sighted people as part of the design process.

Learning from experience

Two or three years into the life of a new building, feedback should be sought from building users on the efficacy of the design. Unfortunately, however, it is not normal practice to invite the planners and designers back to sit alongside the building users and objectively review whether the building is actually meeting their requirements.

We believe this should become standard practice, even a contractual requirement (albeit one without penalties). How else can initial design and planning performance be improved unless property developers, architects and designers learn from the experience of those who occupy their buildings?

Accessibility for all

Clearly, it is both common-sense and sound investment policy to design a building that is accessible to everyone, including people who use wheelchairs or people with sensory loss, whether required by legislation

or not. This important objective should remain at the forefront of the building design strategy.

Just as it is common practice for industrial buildings such as factories to be designed for possible future adaptation or extension, so every building should adopt this approach. The built environment must be able to adapt to meet both the changing needs of society and the demands of the legislators. By building in flexibility through good future planning, it will be possible to utilise opportunities to review the design and meet the needs of disabled people well into the life cycle of the building. With the help of the professional expertise of enlightened architects, designers and developers, it will be possible to create more inclusive design – a better architecture, not just for people with sight loss but for everyone.

[2] Mettler, R. Blindness and managing the environment. *Journal of Visual Impairment and Blindness*. Dec 1987 (10) P478-481

[3] Goldsmith, S. *Designing for the Disabled*, McGraw-Hill, 1967

[4] Bruce, I., McKennell, A. and Walker, E.I.



The Nature of Sight Loss



The nature of sight loss



For architects, designers and developers to create buildings and environments that respond more effectively to the needs of blind and partially sighted people, it is important that they should have some understanding of the nature of sight loss.

Only five per cent of people with sight loss have no sight at all. The remainder will have varying degrees of vision which will enable them to see to different degrees. The nature of sight loss varies considerably between individuals. The overall picture is complex, but generally the result of different eye conditions will lead to the following types of sight loss:

- a limited field of vision, being unable to see the sides or up and down;
- some loss of central vision limiting the ability to see fine detail;
- severe short-sightedness, seeing the world as a continuous blur;
- uncontrollable oscillations of the eyeball leading to an inability to see objects clearly;
- night blindness, a sensitivity to light and a tendency to be dazzled by glare.



Full sight

All the relevant detail is instantly visible and there would be no problem negotiating the area. The next four examples show how the same scene would look with various eye conditions.



Cataract

The scene begins to blur, some key features begin to merge and the detail is drastically reduced; signs would be difficult to read.



Macular degeneration

No central vision makes wayfinding extremely difficult even though peripheral vision remains. Signs would be impossible to read.

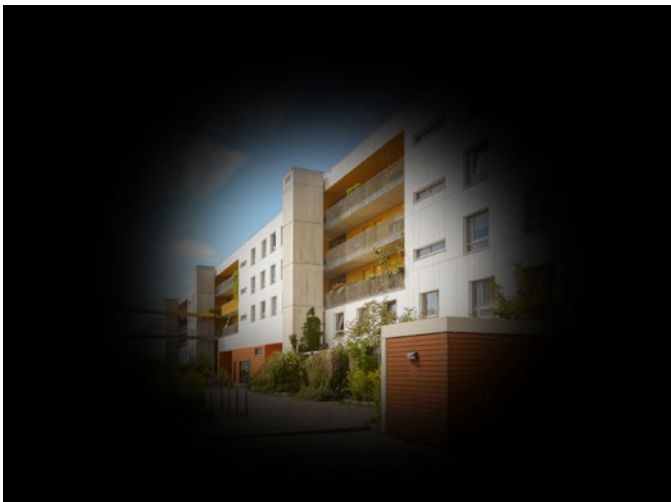

Tunnel vision

A very small central part of the scene is visible giving no warning of hazards and making progress very slow.



Diabetic retinopathy

Patchy vision results in lack of sharpness across the visual field; the scene merges together making it almost impossible to see which way to travel.



Types of sight loss

In broad terms, sight loss falls into two main groups, although in practice there is some degree of overlap between the two.

Loss of sharpness across the visual field

This is where the individual experiences a loss of acuity right across the visual field. The term visual field refers to everything that can be seen at a glance: when looking directly at an object we still see things above, below, and to the sides of that object, as well as other items sited beyond it. This loss of sharpness in the visual field will mean that the individual affected will see the world in the form of a degraded picture. The degree and severity of the condition will determine the visual quality of the image seen.

If the loss is small, it will render the individual's view of the world as slightly blurred with objects appearing a little unclear. In this case, detail will begin to merge into a 'definable with difficulty' image. As the eye condition increases in severity, the perceived image becomes progressively blurred and indistinct. As it does so, objects become less definable and will merge into an indeterminate whole. At this point the world will be seen as a series of splotches, blurs and indefinable shapes all coming together in a kaleidoscope of moving patterns and tones.

Areas of 'non vision' within the visual field

This loss in the visual field can be either in the central area, as in macular degeneration; peripheral, as in glaucoma or some types of retinitis pigmentosa; or it can be combinations of the two, producing a kind of patchy vision which is sometimes associated with retinal problems or diabetes.

A loss in the central area is the most common among older people; over 60 per cent of those who are registered have this form of sight loss. This type of loss makes it difficult to see detail and perform near-vision tasks such as reading, sewing, and recognising people. An accompanying loss of colour perception is likely and so difficulties may arise in detecting subtle variations in colour. However, peripheral vision – which even in sighted people is progressively more blurred towards the edges of the visual field – is seldom affected. This means that the individual's ability to move and negotiate objects is less affected than might at first be thought.

Casual observation of someone with a central sight loss will reveal apparent contradictions in performance of everyday tasks. On one hand, the person appears to move around with relative ease and a good degree of



safety and independence, even though he or she is unable to read notices or recognise friends in the street. Someone with sight loss will be able to see where objects are situated but will experience varying degrees of difficulty in determining exactly what they are.

Familiarity with an area plus life experience are also factors in this equation. In familiar places, the person will move in a much more relaxed way than on unfamiliar terrain. This might seem obvious but what is less easy to understand is how that person uses their life experience to interpret their environment.

As an example, imagine a street scene: The pavement stretches ahead into the distance and there is a high wall on the left. On the edge of the pavement there is a rectangular red 'something' that stands vertically. This 'something' is very blurred and the person with a central loss will not see the object when looking directly at it. The detail which normally helps to identify the object will be merged into its overall image giving little or no help. But life experience will quickly identify this red 'something' as a pillar box and the position of the slot into which the letter must be posted will be relatively easy to locate.

It must be borne in mind that wherever the eye is looking, the area of 'non vision' will follow. This will obscure detail and make it difficult to see the desired line of travel and whether any object lies in the way. However, it will be noticed that peripheral vision is not affected. By using a technique known as 'eccentric fixation', the line of travel / object can be placed outside the central spot and although detail will not be sharp, there will be sufficient information to identify whether the way is clear or not. In other words, the traveller with this type of vision must learn not to look at what he or she wants to see.

This eccentric fixation technique is one which is not easy to acquire, particularly in old age. After a lifetime of 'conditioning' in which the person has used central vision in order to see clearly what they are looking at, beginning to learn new techniques of seeing requires a high level of determination and motivation on the part of the person concerned.

It must be remembered that even with eccentric fixation the image perceived will not be anywhere near as sharp as previously experienced. At best, sufficient detail will be revealed to render the object more interesting or negotiable. It should also be pointed out that anyone with this condition



will always have a central 'blank' area no matter how much they move their eyes. Eccentric fixation merely moves the image perceived by the eye onto a better part of the retina away from the now damaged central part. Therefore, every time the eye moves, the central blank area moves also.

Glare problems

There are several eye conditions which are adversely affected by glare. The most common of these is cataract which is an opacity of the lens of the eye. The area affected and the degree of vision present will clearly be determined by the size and density of cataracts, and therefore the simulation is approximate at best.

A sighted simulation of the effect cataracts have on vision can be experienced when driving a car with a dirty windscreen into an evening sun. The low sun strikes the dirt on the windscreen causing light to scatter, producing a loss of detail and contrast. It is therefore very important that lighting, be it natural or artificial, is provided in such a way as to minimise the effect of glare.

The ageing process

A high proportion (18 per cent) of the population in the UK is over the age of 65, and this figure will increase in the foreseeable future. As people grow older the ability to see fine detail is diminished and the eyes have increasing difficulty in accommodating sudden changes of light or rapid re-focusing, such as when looking up from a task to a distant or near-distant object.

This is in part due to physical changes in the structure of the eye which affects the lens, and other elements within the eyeball, as well as the muscles which surround it (see Appendix a: How the eye works).

Changes in the transparency and thickness of the lens will inhibit the passage of light. In addition to this the muscles of the eye become weak, leading to focusing difficulties and a reduced pupil size, which in turn limits the amount of light reaching the retina still further. The implication for this is clear to see. Older people need more light. In fact, roughly twice the amount of light is needed at the age of 60 than at 40. It is also thought that, generally speaking, someone with sight loss will need between 50 per cent and 100 per cent more light than their sighted counterparts, and in some cases even more.



Tunnel vision

The type of sight loss commonly known as 'tunnel vision' causes those affected to lose all, or most, of their peripheral vision whilst retaining normal acuity in a reduced central spot. 'Tunnel vision' is something of a misnomer as it implies that the person sees a reduced area of the scene surrounded by an area of blackness. This is not the case, even if the loss of peripheral vision is total. The visible area will be reduced, but there will be no surrounding blackness.

In severe cases of tunnel vision it may be necessary for the individual to 'scan' the area in order to locate the visual information which is being sought. This scanning technique must be repeated with each step the person takes to ensure that relevant information is gained at the last second and that the way ahead is clear.

One of the difficulties with this type of sight loss is that mobile objects at the side suddenly come into view, leaving little time to avoid a collision. Also low objects may remain undetected, particularly when the sufferer is focused on their destination. It is easy for someone walking across a crowded room to fall over low objects such as furniture outside the field of view.

Peripheral vision also enables us to see in the dark, and so severe peripheral loss diminishes this ability, which in turn will affect the person's mobility in variable lighting conditions. There are many apparent contradictions in this condition. People with peripheral loss may grope about in the dark and will be almost totally blind, but if lighting conditions are 'just right' then they may be able to move around with relative ease. They may well be able to read the smallest print in a newspaper, or spot a needle on the carpet whilst sitting in an armchair, but when moving they may start to collide with objects.

A combination of visual loss

In some eye conditions the effect on vision is, or can be, a combination of all these factors. In other words, the person can experience a degree of loss in the central field and also various losses within the peripheral area, producing a 'patchy' type of vision. The position and size of this 'patchiness' will determine how the individual sees the world and the density of these patches will affect the amount of detail which becomes visible. People with this condition will see the world differently, depending on the position and size of the blank areas.



When someone incurs damage to the optic pathways between the back of the eye and the visual cortex, the same side of the visual field is affected in both eyes and, in many cases, the whole of one side of the visual field is lost. From the mobility point of view, the biggest problem is the loss of peripheral vision on the side which is affected, with the inevitable result that collisions are likely to occur with both stationary and mobile objects, and people situated on that particular side. Reading signs and notices may also be difficult (see Chapter on Signs and Notices, pg 67).

Mobility aids

The most common aid used by people with poor sight to facilitate their mobility is another person's assistance.

A sighted guide will normally walk by the side but slightly ahead, of the person with sight loss who will hold their upper arm with one hand. This form of guidance obviously has implications in terms of door widths, corridor widths and so on.

The second common aid used by people with poor sight to facilitate their mobility is a white cane. There are a host of different types, but the most familiar is the one used to scan the ground in front of the person. This scanning takes the form of sweeping the cane in an arc

from one side to the other to just over the width of the body. This technique only locates low level items in the immediate vicinity. Overhanging objects above approximately 300mm will be missed by the cane.

People with sight loss may have a guide dog to assist them. According to Guide Dogs (2022), there are approximately 4,800 guide dog owners in the UK.

Guide dogs are also limited in their ability to detect overhanging objects. If collisions and possible serious injuries are to be avoided, then hanging and/or projecting hazards must be indicated or protected at ground level or, better still, eliminated altogether. Working with a dog raises issues with regard to door widths, and so on. A person with a guide dog generally requires more width than a wheelchair user, and if shopping or other baggage is being carried, ample width is required for easy passage.

If pathways are to be easily identified with peripheral vision (which is blurred in everyone) they must be differentiated from adjacent walls. Any objects situated on them will need to stand out so that they can be recognised as an obstruction. Items such as notices or signs may be seen as little more than a rectangular shape on the wall or suspended from the ceiling, with the print perceived as a series of wavy lines and swirls.



Generally speaking, the person with a central loss will view objects in gross terms, all details and textures merging into an indefinable mass; nevertheless, they will still be 'seen' and dealt with in the appropriate way provided they contrast with the background against which they are seen.

Implications for building design

It will be apparent from the above that all of this has significant implications for the building and interior design process. A design checklist is shown on the next page.

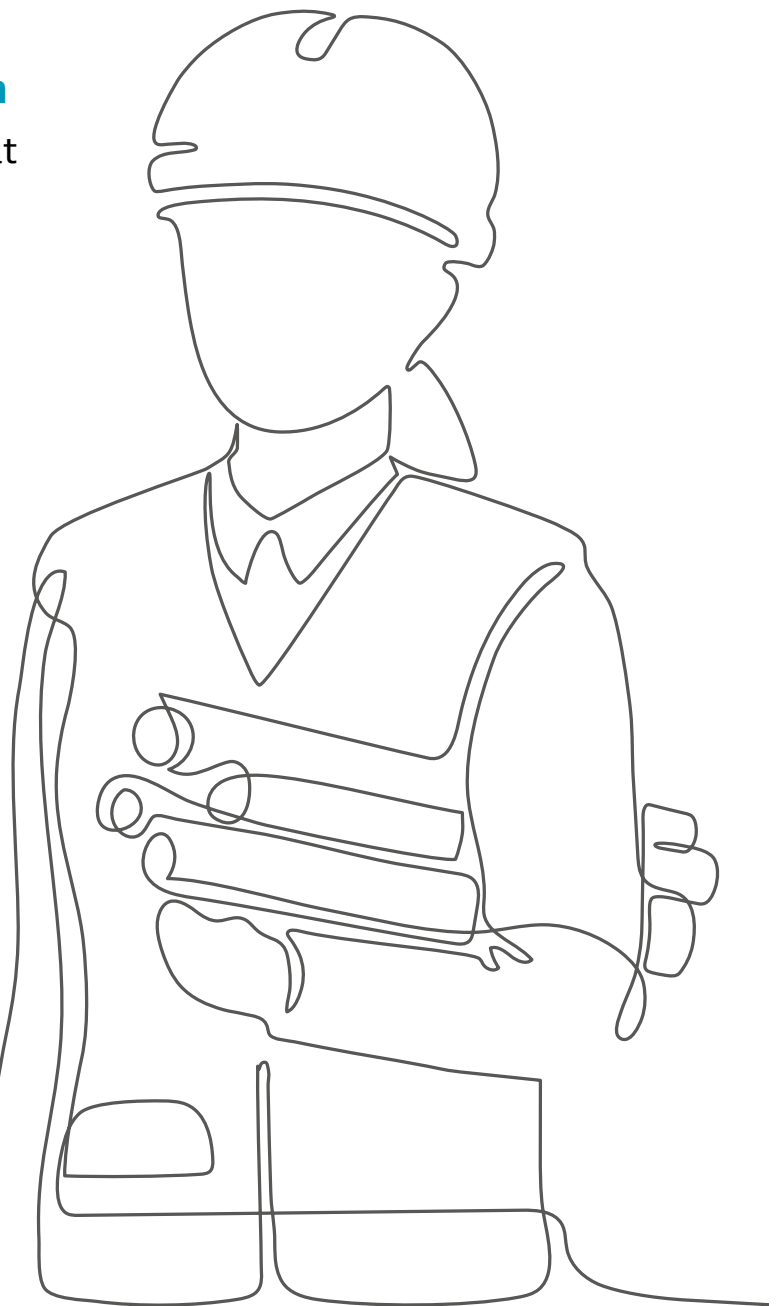

Design checklist

Layout

Forming a clear mental picture of a building and its surroundings is made much easier if there is a simple, logical layout. Once formed, this mental picture is also more easily memorised for the future when the building design is straightforward and rational. To a certain extent, logical planning can be helpful in helping people to anticipate probable locations: stairs situated next to lifts, for example, or male and female toilets located next to one another.

More detailed issues about building layout are dealt with later in this book.

Visibility

If the key features of a building are visually accentuated this can be very helpful to people with sight loss. For example, columns in circulation areas should be coloured to stand out from the background, not merge in with it.

The same logic of visibility and differentiation should be applied to a whole range of building features – handrails, stair nosings, doors, glass panels, light switches and so on. Colour and tone contrasts are the most effective means of improving visibility, with tone contrast usually the more effective. A conventionally pleasing co-ordinated colour scheme can usually be significantly enhanced with good tonal contrast.

Lighting

Good lighting is vitally important not only to people with sight loss but to all building users. Adequate lighting levels, well-designed lights and proper positioning are all necessary if other aids to visibility are not to be compromised by glare, dazzle and the unwelcome optical illusions caused by heavy shadows.

These three general areas of concern – layout, visibility and lighting – must form the basis of any environment that is to be accessible and welcoming to everybody. The next section of this book expands upon these and other issues that contribute to the concept of inclusive building design.

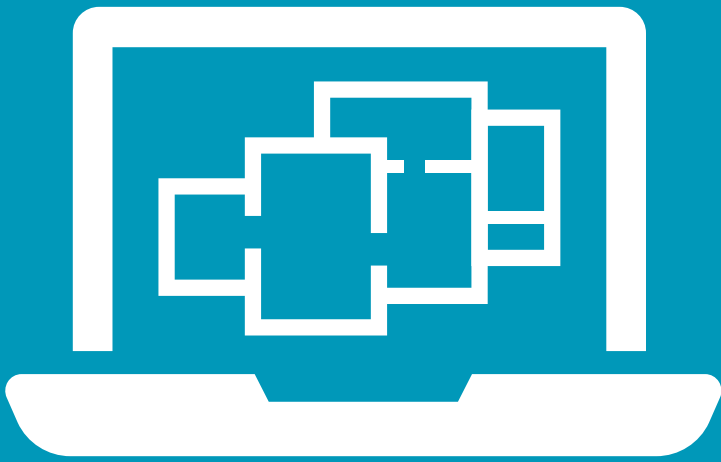

Design Practicalities



Section Two – Design Practicalities

This section provides a reference guide to the design practicalities involved in creating buildings and environments to give a good experience for everyone who interacts with them, including people with sight loss.

From the siting of the building, its approaches, surroundings and entrance, to the fixtures, fittings and finishes of the interior, lighting, signing and design of specific types of facility, a range of key issues are raised and appropriate solutions presented.

Basic principles followed in this section are:

- providing simple lay-out, which is logical and, therefore, memorable;
- use of colour and tone contrast to raise visibility;
- adequate and evenly distributed lighting;
- careful use of touch, sound, fragrance and air movement techniques;
- highly visible, tactile embossed and concise signs.





Site, Street and Surroundings





Influencing site location

In practice, the siting of a new building or group of buildings will often have been predetermined by the developer and planner. In cases where the architect is able to exercise influence, it is important to take into account the needs of all the building users when deciding how to make best use of the site while achieving the optimum shape and orientation to the structure. Ideally, the developer or planner will already have given serious thought to these issues; if not, the architect should ensure that they are fully explored at the earliest possible stage.

Wherever practical, sites should be level and close to all amenities. Routes to nearby amenities such as shops, leisure facilities, public transport systems and housing should be carefully considered to make access direct and safe. It should be appreciated that disabled people rely heavily on public transport. Where changes in level are unavoidable, ramps / slopes should be used. The necessity to cross busy roads or negotiate cluttered areas should be kept to an absolute minimum.

The whole site should be made accessible to people with a wide range of impairments. Sites that manage to achieve this are user-friendly for everyone, including older people

and those with prams. It is always worth remembering that the best integrated schemes can be spoilt by lack of attention to detail: a caretaker's house with steps to the door, for example, or large spaces with no mobility wayfinding aids for people with sight loss, can undo much good work in other areas.

Access routes

The surfacing on pedestrian routes approaching or surrounding the building should be firm, even, and level; it must not become slippery when wet. The crossfall should not exceed 1:50 because an excessive crossfall or camber may cause a blind person to deviate from the correct route. Where a route is paved with slabs, the gap between adjacent slabs should not exceed 5mm, and the vertical deviation should be kept to a minimum, not exceeding 10mm.

The edge of a pedestrian route should be clearly defined, either by a kerb or by a distinct change of texture, such as grass or gravel. Incidentally, gravel paths are not a good idea since they are virtually unusable by wheelchair users or those with mobility impairments. An upstand should have a minimum height of 150 mm.



Handrails can be a very effective way of providing additional guidance to people with sight loss, as well as support to others. These should be colour-contrasted with the background. They should be smooth and comfortable to the touch, with no sharp edges or corners. Handrails should be fitted to both sides, continuous, extend a minimum 300 mm beyond the start and finish of a ramp or the last nosing of a stair, at both top and bottom, and terminate in a way that reduces the risk of clothes being caught, preferably by returning to the floor or wall.

Where footpaths lie on a significant gradient, horizontal resting places with a level surface should be provided at frequent intervals. Research has indicated that 50m is the maximum distance that can be comfortably covered at a stretch by many people, particularly those who are older or with mobility impairments. Resting places on a sloped path might therefore be introduced at slightly shorter intervals – say 30m.

Drainage grilles should be offset from pedestrian routes and set flush with the surrounding surface. The gap between grille bars should not exceed 13mm, and bars should be set at right angles to the direction of travel, so that they do not present a potential trap for the tip of a long cane.

Street-level aids

There are a number of design issues to consider in relation to approaches to the building and its surroundings.

Tactile paving surfaces: The ground surface or floor covering has a significant effect on the appearance of an area and it can also be a useful source of information. A number of different profiles have been developed, each of which has a specific meaning, and they are available in a variety of materials and colours providing flexibility and choice. It should be emphasised that the integrity of the profile must be maintained, and the surface must always be used in the correct application.

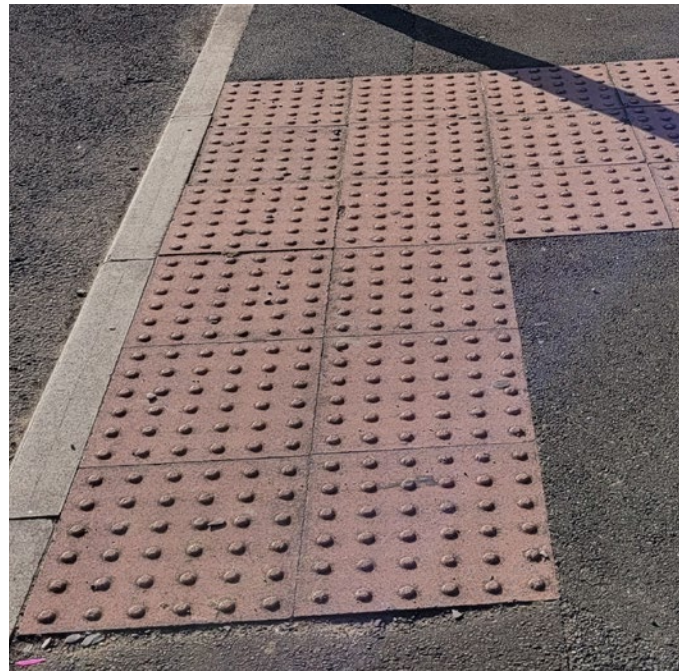

■ Contrasted tactile paving at zebra crossing.



The most used pattern is the blister, which should be used at a dropped kerb or raised road surface to indicate the edge of the footway and the start of the carriageway. Some other specified surfaces used in streets are shown here. It is essential that each tactile surface is used consistently throughout the nation for the surface to be useful to people with vision loss. See Department for Transport's Guidance on the Use of Tactile Paving Surfaces for further detailed information.

Blister paving: Small, regular flat-topped domes warn pedestrians with sight loss of the absence of a kerb upstand at a crossing where the kerb has been dropped, or the carriageway raised, to assist wheelchair users and others to cross. The blister paving enables pedestrians with sight loss to differentiate between the footway and the road. The tactile paving should contrast with the surrounding footway surface. A red paving surface should be used at controlled crossings, and a stem of blister paving extending to the back of the footway alerts pedestrians of a safe place to cross.

- On a 450mm square blister paving the distance between each blister centre would be 64mm and there would be 7 blisters in a row.

- A standard design 400mm square blister paving the distance between each blister centre would be 66.8mm. On this slab there will be 6 blisters in a row.

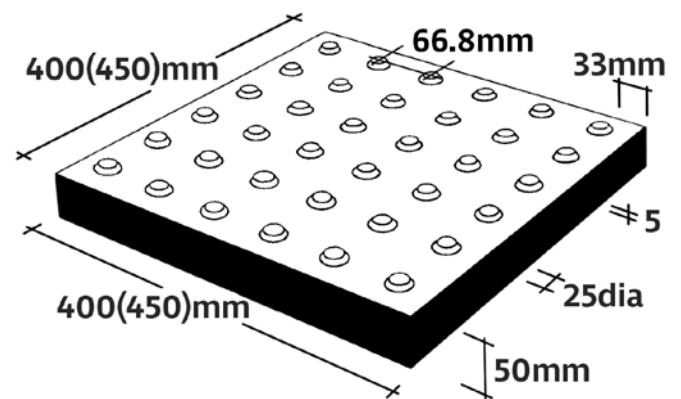

■ Blister paving.



■ Blind person using a cane whilst walking on a tactile paving area.



Directional guidance paving: Round ended bars which are used to guide pedestrians with sight loss through a large, open space e.g. a pedestrian precinct or a town square. The bars are laid in the direction of travel and turned at corners to give warning of a change of direction.

- The 10mm reference is the space between end of the raised bar and edge of slab, so there will be 20mm gap when each raised bar is lined together.
- With 5mm being the recommended height of the bars with a 0.5mm tolerance in measurement as shown below:

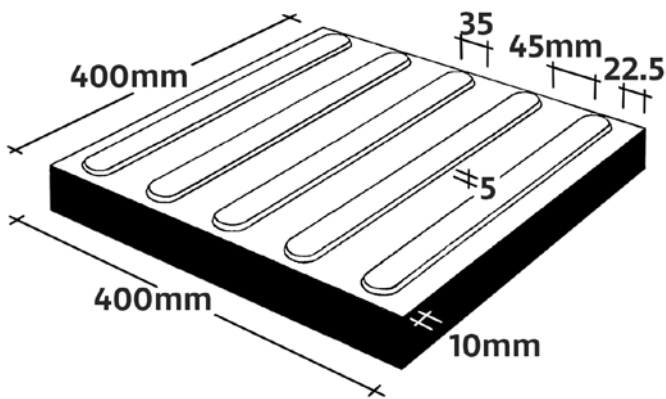

■ Directional guidance paving.

■ Directional guidance paving.

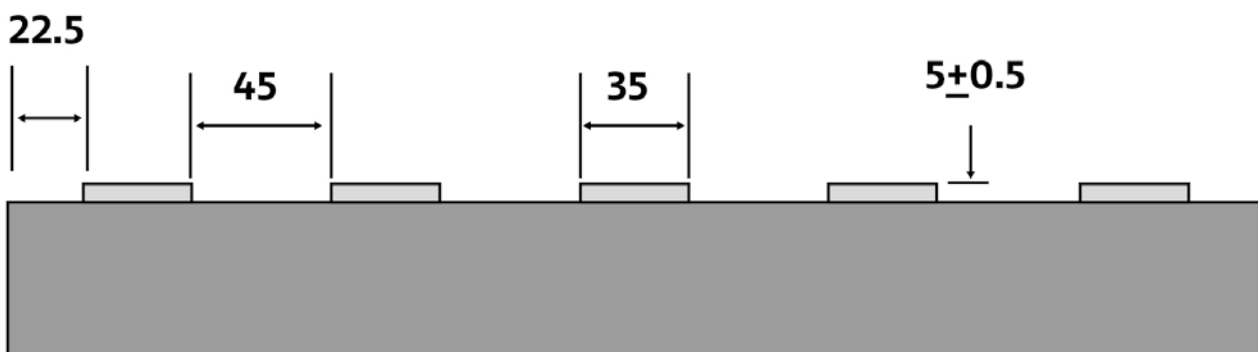

■ Directional guidance paving – side view



Hazard warning paving (corduroy):

A pattern of half rod-shaped bars to give warning of a hazard which requires caution e.g. at the top and bottom of a flight of steps, at the approach to a level crossing, and at the approach ramp to an on-street light rapid transport system. It means 'hazard, proceed with caution'.

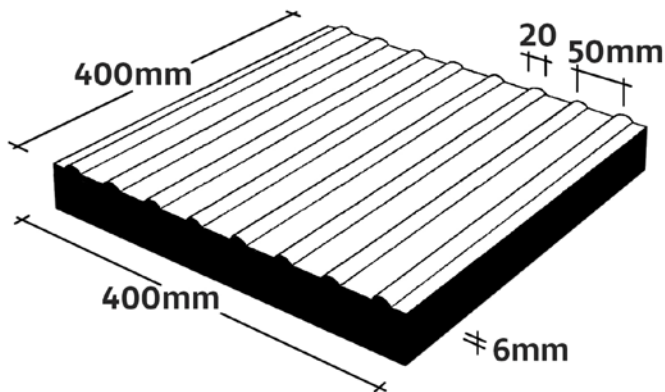

■ Corduroy paving.

Cycleway paving: The bar pattern is laid on shared pedestrian/cycle routes which are not segregated by level. The paving is laid transverse to denote pedestrian use, and longitudinal to denote cycle path. Where a cycle track runs parallel, and on the same level as, a footpath, separation of the two is preferably achieved by a grass verge or other distinct change of surface dividing the footpath from the cycle path. In circumstances where this cannot be achieved separation may be provided by the use of the fourth tactile surface pattern, a continuous bar, laid transversely (pedestrians) and longitudinally (cyclists), with a raised dividing line (central delineator) between the track and footpath.



■ Corduroy paving at steps.

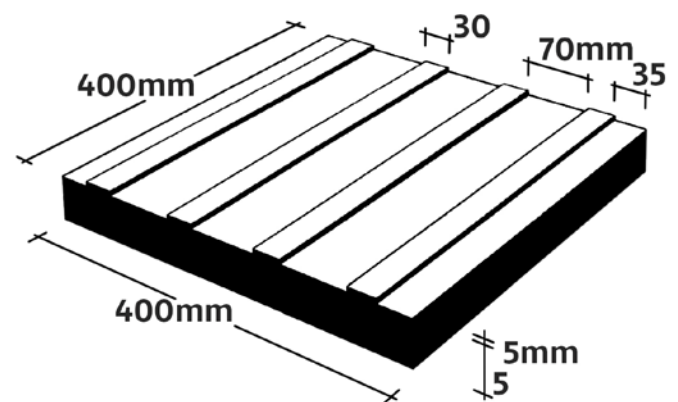

■ A raised central delineator separates the pedestrian and cycle sides.



Crossovers: Wherever practical, a crossover should be set flush with the pavement, while being distinguished from it by a different texture and different colour surfacing. There is normally no need to indicate the crossover by tactile paving. However, if it is located at a busy entrance to premises like a garage, hospital, or factory, then other considerations arise. It may, for example, be necessary to treat the crossover as if it were a side road by providing a dropped kerb and tactile paving.



- Contrast paving to denote vehicle crossover.

Road crossing: In addition to a tactile paving surface, other features of a controlled crossing are audible as well as visual – there is indication of crossing phase and a tactile rotating cone positioned under the control button to assist disabled people to know when to cross.



- Tactile paving to indicate a zebra crossing.



- Colour and texture changes alert people to the difference between footway and carriageway.



Traffic-calming features

Some techniques for reducing traffic speed pose particular problems to pedestrians with sight loss. The best indicator to a person with sight loss that they have reached the edge of the pavement (footway), and are about to step onto the road, is the conventional kerb. If that is removed by raising the surface of the road, or carriageway, to the same level as the pavement, the effect can be confusing and dangerous. The change of footway into carriageway must be indicated by appropriate tactile paving. The message should also be reinforced by providing a different colour and texture of paving between the footway and the carriageway surface.

Bollards: badly designed or poorly positioned bollards are potentially a serious street hazard. A knee-high, natural coloured concrete bollard can cause severe injury to an unsuspecting pedestrian.

Bollards should be a minimum of 1m in height, and colour/tonal contrasted with the background against which they are seen – for example, a black bollard against light paving or concrete. There should also be a colour contrasted band around the neck of the bollard as a further aid to visibility. The bollard should not have any ornamental features projecting horizontally, and under no circumstances should adjacent bollards be linked with chain or rope.



- A Dark Bollard on light paving highlights the bollard for people with sight loss. The bollard also has a light coloured top and collar to further enhance its presence.



Street furniture: Street furniture such as lighting columns, signposts, litter bins, seating and so on, are necessary and desirable features. However, once again, if they are not properly designed and positioned, they can be potential obstructions and hazards. They should be positioned out of the line of pedestrian travel, off (but adjacent to) the footway and effectively highlighted with colour and tonal contrast. For example, a signpost painted black to contrast with a light paved background should also have a white or light-coloured band around it at eye level. This band should be 150mm deep with its bottom edge at between 1.4 and 1.6m above ground level.

In some cases, it may be necessary to have a low-level sign or notice board, such as near the entrance to a park. Sometimes such a sign is supported on two vertical poles, set far enough apart for an unsuspecting pedestrian, or a child, to walk between the poles and collide with the notice board. This can be prevented by the provision of a low-level rail between the posts, which should also be suitably colour contrasted to make them easier to detect. It is important that this low rail is no higher than 250mm above ground level. This will also prevent a guide dog from walking between the posts. In addition, the extension of the sign beyond the vertical post on either

side should not exceed 150mm, to prevent a pedestrian walking into it.

Benches and seats should be offset from the pedestrian route and colour contrasted so that they are clearly visible against their background. A light colour is helpful when the background is of dark vegetation. Litter bins, if they are free-standing, should be continuous to ground level. A pedestal mounted basket which overhangs its support, could easily remain undetected by a white cane user and cause injury at hip or waist level. Litter bins should contrast with their background and be made with materials that will not cause injury if the litter bin itself is damaged.

Sharp corners and edges which could trap fingers or tear clothing, should always be avoided.



- Obstruction along main line of walk is a typical hazard to people with sight loss.



Vegetation

Vegetation can add enormously to both the attractiveness of an open space, and the orientation of people with sight loss, if appropriately chosen and positioned. Trees and bushes should be positioned so that they do not present too much of a maintenance problem by overgrowing footpaths. A branch overhanging a footpath can cause serious injury.

There should be constant maintenance or a policy of planting the vegetation well back from the edge of the footway.

Falling leaves, cones, nuts and so on, can all present problems to disabled people, and particularly those who are elderly, as the surface may become slippery, or uncomfortable to walk on.



- Overhanging trees and foliage threaten the safety of people with sight loss.

On the positive side, many plants can act as useful landmarks and, therefore, aids to orientation. This may be because the plant has a particular fragrance, colour, or very distinctive shape.

Open spaces

Large open spaces, as found in shopping precincts or pedestrianised areas, can cause wayfinding problems to people with sight loss. Unless there are sufficient landmarks available, following a particular route can be extremely difficult, if not impossible. The strategic use of guidance paths (see tactile surfaces) and landmarks can aid orientation. Contrast textures and colours of surfaces can be used to denote areas used for different functions, such as rest areas and play areas. Distinct profiles have been developed to indicate a guide path and 'proceed with caution' or 'hazard ahead' warnings.

Approaches

If the approach to the building cannot be level, there should be a gentle gradient, preferably not exceeding 1 in 20. If ramps are used, there should be a handrail on both sides, and there should be a ground level upstand, kerb or tapping rail. The upstand at the edge of a ramp should be a minimum height of 100mm, and no more than 200mm. A tapping rail, or kicking rail, should be positioned so that its top edge is no higher than 200mm above ground level.



Steps should be provided in addition to a ramp. They should also be properly equipped with handrails on both sides and with a highlighted or colour contrasted nosing extending the full width of each and every step. In the case of a strip, it should be as close to the edge of the step as possible and should provide effective colour contrast so that the edge of the step is clearly visible in all lighting and weather conditions. Nosings should be between 50-65mm in depth on the tread of the step and on the riser should be between 30-55mm, and the material used should sit flush with the tread and riser.

Although there should be a tactile warning at the top and bottom of the stairs or steps, it should not normally be used at the top and bottom of ramps. Dimensions for ramps, steps and handrails, are given in the next chapter "External Design", pg 39"



- Ramp on approach to building that has a contrasted gradient to the level surfaces including the landing area.

Seeing Streets Differently (2021)

RNIB's publication 'Seeing Streets Differently' (2021), [rnib.in/InclusiveStreets](https://www.rnib.in/InclusiveStreets) highlights several issues for streets and external environments that have arisen since the original publication of Building Sight. These include:

Shared space areas: pedestrians and vehicles often share an area without clearly identified pavements, which presents a significant barrier to independent mobility for people with sight loss as they rely on pedestrians and vehicle drivers negotiating priority and movement through eye contact.

There has also been a trend to remove signal-controlled crossings and replace them with zebra crossings or courtesy crossings. These types of crossings, particularly courtesy crossings, are much less safe. People with sight loss need signal-controlled crossings where they can rely on traffic stopping to enable them to cross safely.

While pedestrians now have right of way at zebra crossings, it is not always obvious to a pedestrian with sight loss whether they are at a zebra or a courtesy crossing. This can cause confusion and can be dangerous if the pedestrian mistakenly assumes they are at a zebra crossing – and has right of way – and steps onto the crossing.



There must be a sufficient number of accessible signal-controlled pedestrian crossings over roads and cycleways in the right places to help people navigate, particularly along routes to essential services, e.g. transport hubs, shops, offices, hospitals, schools and health and community facilities such as parks. Given the challenges the increase in quiet vehicles present for people with sight loss, accessible signal-controlled crossings are also necessary in lower traffic flow areas.

Quiet electric vehicles: while the environmental benefits of electric vehicles are recognised, the loss of engine sound is a concern as people with sight loss rely on hearing vehicles. RNIB has called on the government to require Acoustic Vehicle Alerting Systems to be fitted to existing electric and hybrid vehicles, bring forward a law to prohibit these being switched off and, in the meantime, raise awareness among electric vehicle drivers of the importance of keeping these turned on. Electric vehicle charging points must be accessible and ensure that cables do not obstruct pedestrian paths.

Bus stop bypasses: these divert cycleways around the back of bus stops so that cyclists do not have to wait behind or overtake a parked bus. The impact of this is that blind and

partially sighted people – who are often particularly dependent on public transport – must navigate fast-moving silent cycle traffic in order to reach the bus stop, or when leaving a bus in order to reach the pavement, which can be extremely intimidating. Controlled crossings where cyclists are required to stop must be provided to enable pedestrians to safely use buses.

Rental dockless bike schemes: these allow people to hire bikes which are located through a smartphone app. As the name suggests, dockless bikes do not need to be returned to a fixed docking station and consequently bikes are often left as obstructions on pavements creating hazards.

Electric scooters: these near-silent fast-moving vehicles pose a persistent risk to people with sight loss. RNIB wants to see the rules on not using e-scooters on pavements enforced, adequate off-pavement parking provided, and the appropriate street infrastructure in place to keep pedestrians safe.

New types of transport technology: driverless vehicles, drones, and autonomous delivery pods must have accessibility considerations built in from the start to ensure they do not compromise the safe independent mobility of people with sight loss and other disabled people.

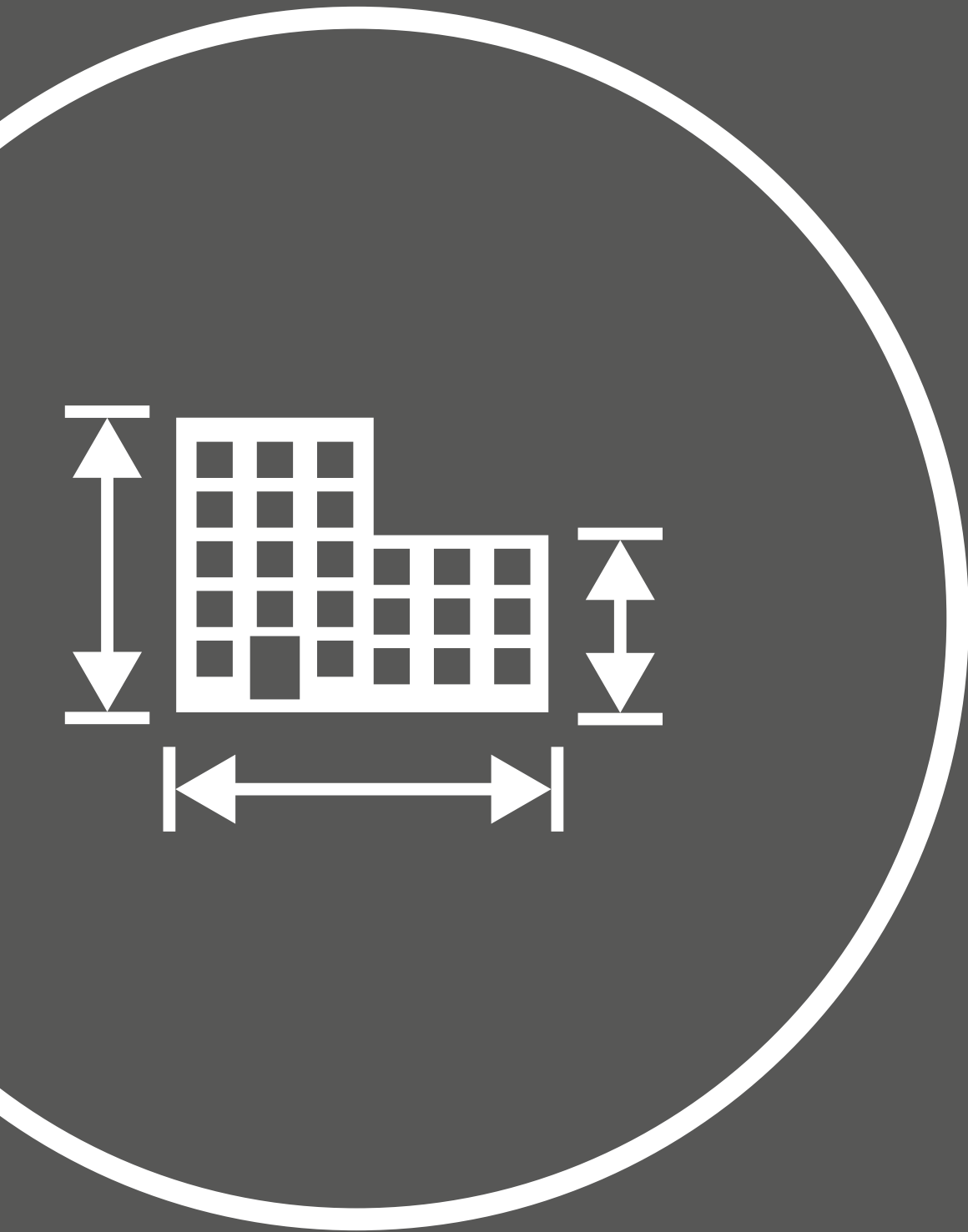

External Design



External Design



Entrances

Just as the building itself must be identifiable – perhaps by its distinctive shape, the landscaping around it, effective signing or perhaps even its use of tactile indicators – so should the entrance.

Unfortunately, there are too many examples of buildings with single glass panel doors which are indistinguishable from similar fixed panels stretching out in both directions. The entrance to a building is important and its design should make it recognisable and inviting.

Entrance canopies

Where an external canopy is used over an entrance, either as protection or as a feature, any supporting columns must not present an obstruction on the entrance approach. Columns and canopy may then be used positively to help identify the entrance. The area underneath the canopy should be adequately illuminated during the hours of darkness.

External doors

The choice of door type is most important. Automatic sliding doors are strongly recommended as these are the easiest to use for people with sight loss, and provide the least barrier to disabled people or older people with

reduced mobility, as well as to those walking with children, carrying luggage, or pushing a pram. An opening width of 1.2m is needed to cater for a person with sight loss plus a sighted guide (a blind person plus a guide dog is 1.1m).

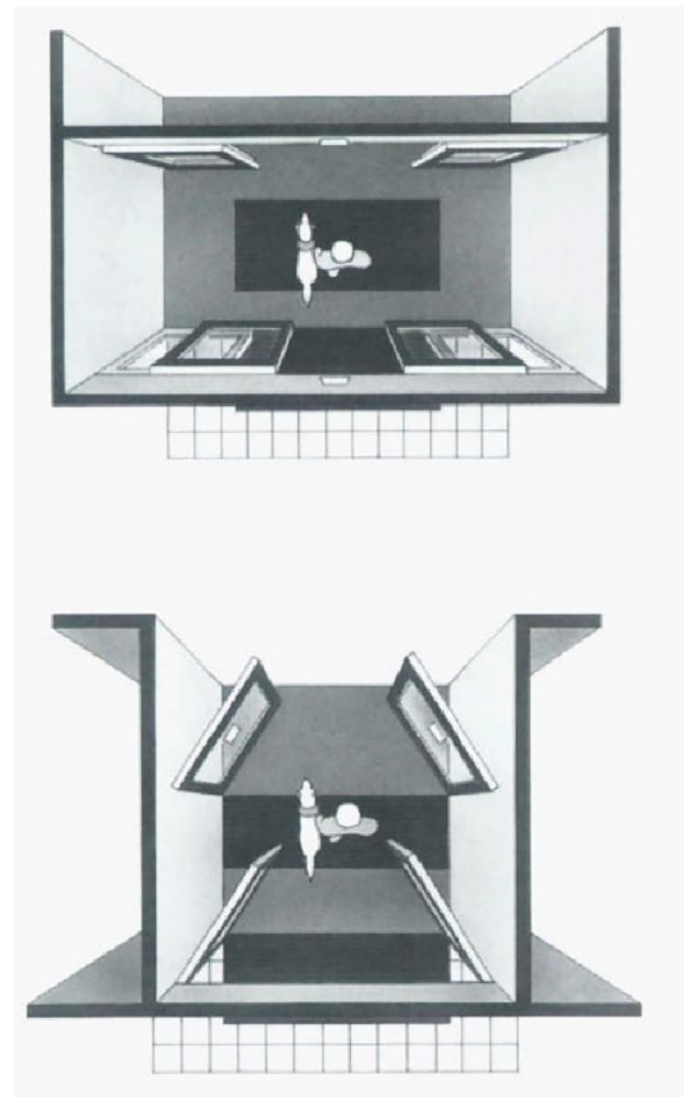

- External doors should be wide enough to accommodate a blind or partially sighted person with a guide dog or helper. A minimum of 1.2m is recommended.



Automatic hinged doors are potentially dangerous unless the leading edge is protected so that an unsuspecting person cannot walk into it.

Where side-hung doors are used, care must be taken to ensure that the spring pressure is sufficient to keep the door closed without making it difficult to open. Door closure springs should be set so that the opening force, when measured at the leading edge of the door, is not more than 30 Newtons (N) from 0° (the door in the closed position) to 30° open, and not more than 22.5 N from 30° to 60° of the opening cycle.

Manually operated power-assisted doors are not useful for people with sight loss due to the difficulty locating and using the control pad. Consistently positioned activation buttons, located on the latch edge of the door, with an effective visual contrast, may assist regular users.

Door furniture should be conveniently positioned with a handle of the lever type, visually contrasting with the door.

The revolving door is a difficult door for all – particularly so for people with sight loss. Anyone who doubts this should just stand by the entrance to a supermarket or hotel where there is a revolving door and adjacent side hung door and watch the choices people make. Most people will use the adjacent

side-hung door or automatic door, unless it is inaccessible or obscure.

The threshold in doorways should be flush. If an upstand or weather bar is unavoidable, its height should be restricted to 15mm maximum and it should have chamfered edges to reduce the risk of tripping.

It is most important to ensure that where ramped access is provided in addition to steps, the two routes are perceived to be of equal importance. Those people who have no option but to use the ramp should not be directed to a secondary entrance.

Distinguishing the door position

The door should be distinguishable from adjacent walls or panels by the use of colour contrasting, lighting and by colour and textural differences in floor finishes. Doormats inside and outside the building can be a useful aid, but care must be taken that they are not trip hazards.

Glazed doors and side panels should be highlighted with prominent signs, logos, emblems or decorative features set across the full width at eye level. Anything smaller than a 150mm square set in a standard glass panel is unlikely to be large enough adequately to signal the presence of the glass.



The material or pattern used to highlight the presence of glass should be at a height of between 1.4 and 1.6m above ground level. It is helpful to repeat this at a lower level too: approximately 850mm to 1m above ground level, and again with a 150mm skirting across the bottom of the glass panel. Whatever highlighting technique is used it must be effective from both inside or outside the building and under any lighting conditions.

Door furniture

Door furniture should be positioned logically, and colour contrasted with the door frame. Door handles on external doors should be positioned approximately 850mm to 1050mm above ground level, and at a consistent height throughout any given building.



- 'Right hand side door panel has just one tone 'white' manifestation, whilst left hand door has two tone 'black and white' which is best practice due to being contrasted to more of background and being more visible'



External staircases

Steps should be uniform, the treads between 300 mm and 450 mm and the riser between 150mm and 180mm. There should also be a handrail on each side and the edge of each step should be highlighted with a contrast nosing with an LRV difference of 60 points. A tactile warning surface should be incorporated at the top and bottom of the stairs. The tactile surface extends 400 mm before the front edge of the first step. The tactile surface contrasts visually with the adjacent ground / floor surface with an LRV difference of 50 points.

The staircase should be adequately and uniformly illuminated during the day and similarly lit at night if it is likely to be used then. The underside of stairs should be enclosed or protected in order to prevent anyone walking underneath them from receiving a head injury on the sloping underside of the structure. Open riser stairs should not be used.

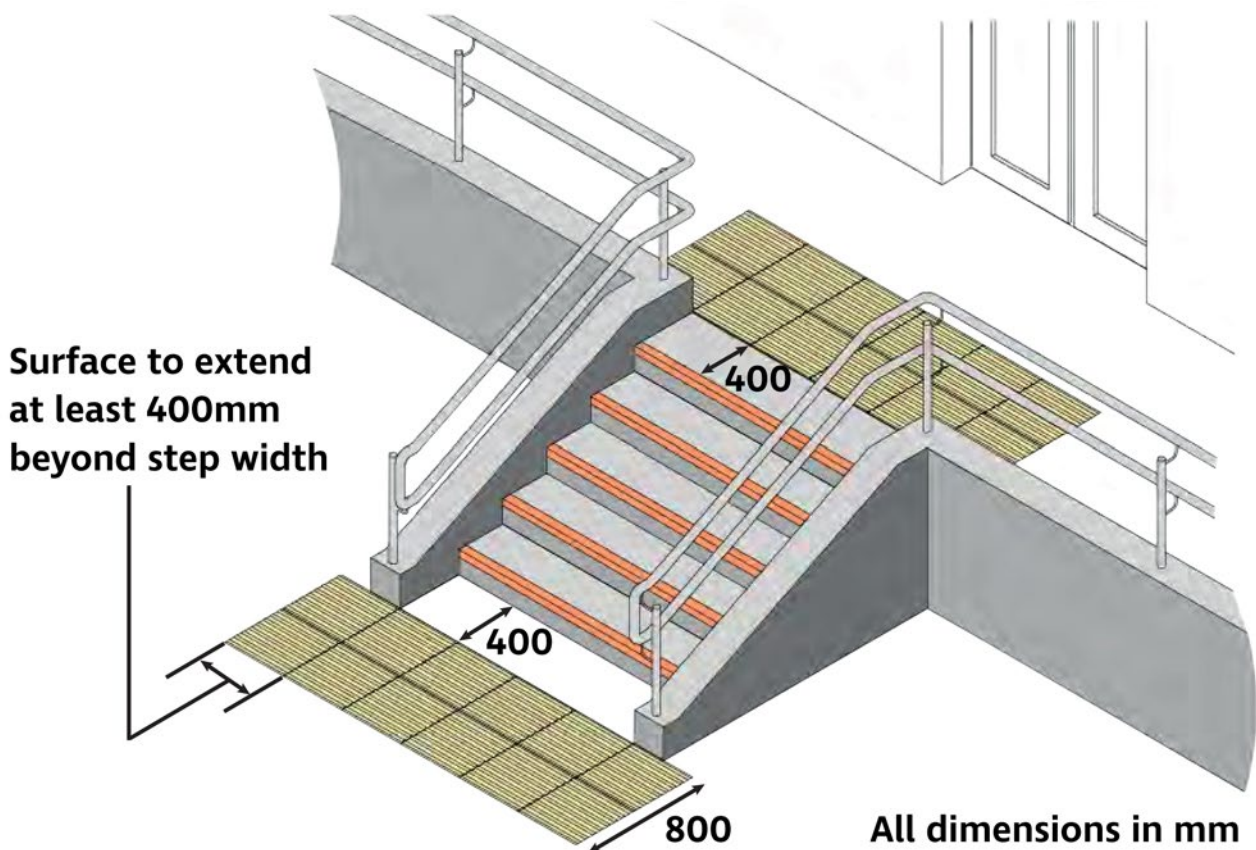



- Unprotected, free standing, external staircase can be made safer if it was enclosed or had planting at its base to stop people running into it.



Lighting





The key issues

Lighting is one of the most important and complex elements of architectural design. Light is the single most important influence in revealing buildings and interiors to their users. The human visual system depends on light to operate, and appropriate lighting is the most important aid to vision. In simple terms – no light, no sight.

As people get older, their lighting requirement increases: a 60-year old will need considerably more light than a 20 year old. People with sight loss generally require up to double the quantity of light needed by sighted people, although in some cases, this may lead to glare problems.

Visual confusion is caused by reflection and glare from shiny surfaces which should therefore be kept to an absolute minimum or avoided altogether.

Care should be taken to ensure that shadows caused by natural or artificial light do not give rise to optical illusions. For example, a shadow could mask, conceal or camouflage a potential obstruction or give the illusion of being the edge of a piece of furniture or part of the building structure. It follows that the means of controlling both artificial and natural light should be provided

where possible.

Recommended Chartered Institution of Building Services Engineers (CIBSE) lighting standards are set out later in this chapter.

General lighting

Uniformity of illumination is of great importance when designing the lighting for a new or refurbished building. Many people with sight loss will find it difficult to cope with extreme variations of light. If CIBSE guidelines are followed, variation should be minimised. Also, there is no point in having expensive light fittings if they are not accompanied by adequate contrast.

What can give rise to problems, however, are variations in brightness that can occur between a luminaire and its background. If a bright light is in the general line of sight, it will tend to determine the adaptation level of the viewer. As a result, looking away to the floor, for example, will make that surface appear darker than it otherwise would. Balance is restored only when the adaptation level is reset. The lesson is to avoid glare by ensuring that all luminaires have an acceptable brightness at normal viewing angles.

It is not the purpose of this book to specify actual luminaires for given areas as the range of available light fitting



equipment is vast. However, it would be sensible, before making a final choice, to see the luminaire lit and mounted at the proposed height so that it can be viewed from all likely angles.

The contrast between the luminaire and its background – normally the ceiling – should be comfortable and there should be no hotspots that might distract. The surface beneath should be evenly lit, with no striations, or discernible patterns, of light.

Fall-off at the edges of the illuminated area should be gradual rather than sharply defined. If the width of the illuminated area – or alternatively the point where the lighting level falls to half that directly beneath the luminaire – can be measured, this gives some guidance to the spacing of the luminaires in a real environment.

Clearly lighting can do much more than just enable something to be seen. It can help to establish where you are in a building, particularly in conjunction with decoration.

A long corridor can be tackled with greater confidence if the far wall is differentiated by light or colour. Illuminated notice boards can mark a boundary; a white push plate on a dark-coloured door can show which side opens; a dark-coloured door in a

light-coloured wall can be found and enhanced if surrounded by a dark-coloured architrave; a spot lit clock on a wall can aid orientation; switches and sockets can be easily found when they are highlighted by contrasting colours.

There are numerous other examples of where colour, contrast and lighting can work in harness to make environments more easily legible.



■ Bright artificial light causes shadows and glare in this entrance hall



On the downside, strong shadows are potentially misleading and can be dangerous. Railway platform lighting with a sharp cut-off can cause travellers with sight loss to 'see' an illusory gap between platform and train. Shadows that make spaces seem longer than they are can cause blind and partially sighted people to walk into walls. The moral is that extreme brightness differences must be avoided: they are more likely to confuse than enlighten.

The requirement to ensure adequate lighting levels in all areas is not only an obligation on building owners and managers but is also a basic consideration in making a building suitable for its users' needs. Appropriate lighting not only makes things more visible to people with sight loss – it also makes the environment a much safer place for everyone.



■ Overhead lighting and no window protection causes areas of glare on the ceiling and floor



■ Glare on computer screens can be prevented by having natural daylight controls in place, such as vertical blinds.



Current UK legislation puts responsibility on employers to provide conditions that do not adversely affect the health and safety of their staff. This means that codes of practice are the only authoritative guides.

The main codes of practice for interior lighting are those produced by the Society of Light and Lighting (SLL) and the Chartered Institution of Building Services Engineers (CIBSE). However, these deal only with the needs of sighted people and make few recommendations for those with sight loss.

There is at present little definitive work which makes comprehensive lighting recommendations for people with sight loss. Indeed, individual needs vary so widely that it is difficult to do so. It is perhaps better to take the recommendations for sighted people as a starting point and modify these in the light of the anticipated needs of those who are blind or partially sighted. This will often mean providing significantly more light – around twice for general circulation purposes – but much more for specific tasks for those who will benefit. At the same time, the option to dim high levels should be retained for the benefit of those who would find it a disadvantage.

From our experience of measuring light levels in various buildings,

it is apparent that even the basic CIBSE recommendations are seldom implemented, let alone any additional lighting to meet the needs of people with sight loss.

The many issues of lighting therefore demand special attention in all new and refurbished building design projects.

Lighting a corridor

Let us take a corridor as an example. The worst way to light it would be by using bare fluorescent lamps installed in fittings mounted widthways. This would cause maximum discomfort.

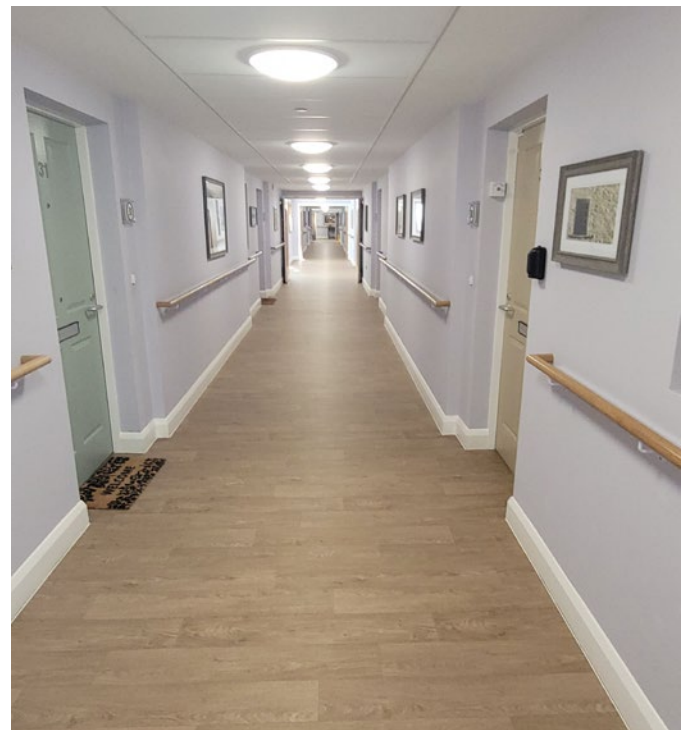

- Well considered light fittings in this corridor minimise the reflection on the smooth walkway



To ensure the corridor is well lit and the light is evenly distributed, ceiling mounted fittings should be positioned longitudinally, preferably down the centre line of the corridor, and lamps should be fitted with well-designed diffusers or louvres to reduce glare.

Now the walls and floor will be relatively evenly lit and such an arrangement should be acceptable, if not ideal, to anyone who finds high lighting levels a problem.

Lighting a stairway

Another common lighting problem is posed by stairways. Here lighting and decor must go hand in hand. The stair covering should not have a pattern that can cause confusion between tread and riser or between one tread and another.

A contrasting colour of nosing can help but this must not be so wide that one step merges into the next when viewed from above.

Changes in direction should be clearly visible, particularly if this involves a change in tread depth which destroys the climbing rhythm.

Lighting on stairs should be sufficient to highlight any obstructions on the flight of stairs but should highlight the treads as opposed to the risers to emphasise each step. It is very important that



■ A badly lit stairwell, with no contrasting features, can lead to a trip or fall.

ceiling-mounted luminaires do not become a glare source – they should be well shielded.

Alternatively, large-area, low-brightness sources can be mounted on a side or facing wall. This has the added advantage of easy maintenance.

A fashion for incorporating lighting into handrails is universally disliked by people with sight loss. The rail usually becomes a glare source at some point in their field of vision.

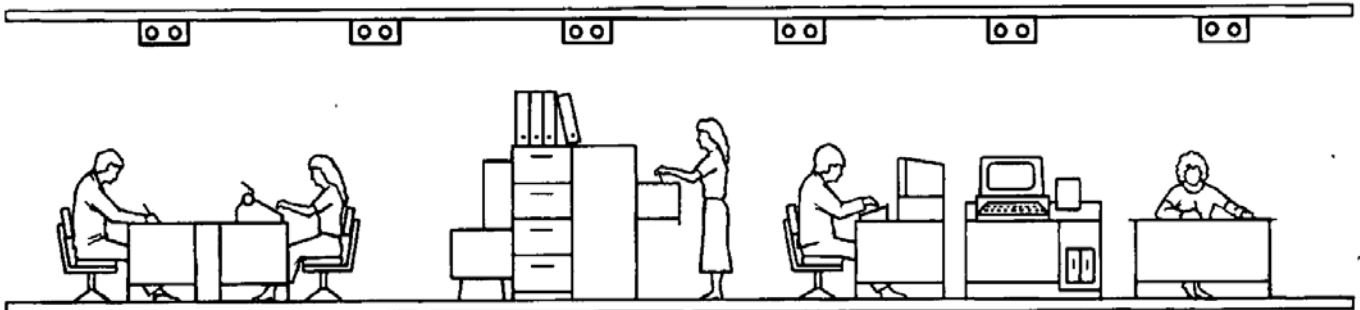

■ General lighting system

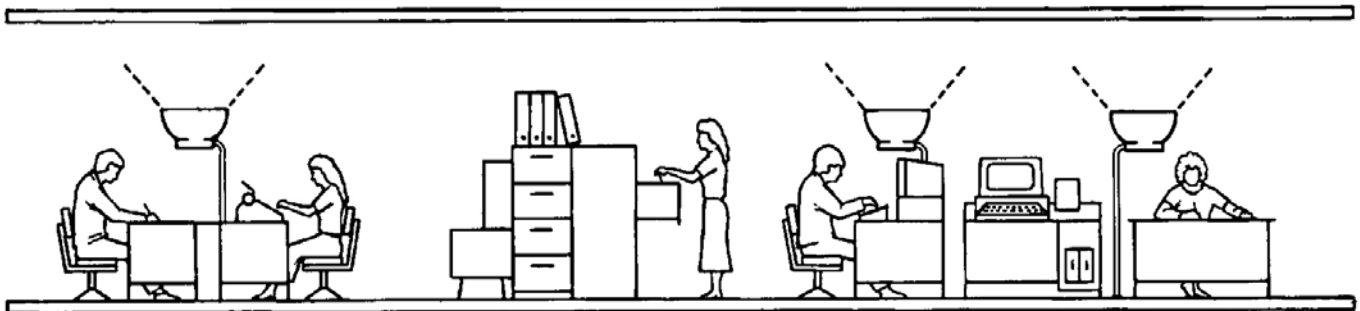

■ Indirect lighting system

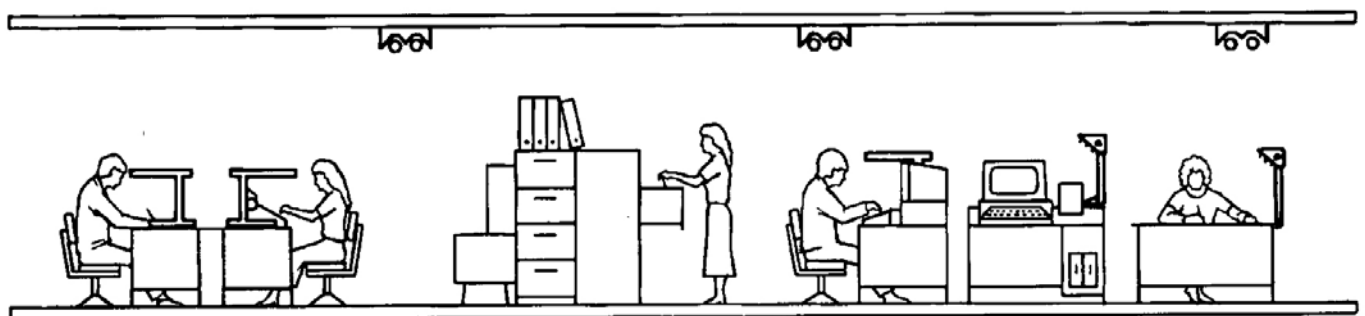

■ Task lighting system



Spotlighting

An area lit only by narrow beam spotlights can create unacceptable contrasts and cause problems of adaptation. However, using spotlights to supplement the general illumination over a small task area can be very



- Spotlights can be used to supplement general illumination.

effective, providing that the general illumination is adequate for normal purposes. For instance, in an office lit to around 500 lux, using an adjustable reading lamp to raise the task area to 1,000 lux or 1,500 lux can be quite acceptable. Using the same reading lamp in an area lit to 50 lux will probably cause problems.

At the other extreme, flat illumination can give rise to problems due to the lack of visual clues, but this is best solved by careful choice of decoration.

Uplighting

The advantages of free-standing uplights are that they can be positioned to suit activities. The inherent inefficiency of bouncing light off the ceiling is offset using very efficient types of lamp.

Reflections off a lit office ceiling on a computer screen are certainly less distracting than those of ceiling-mounted luminaires. However, if the space between ceiling and uplighter is less than 1.5m, a blind or partially sighted person can find an up lit ceiling unacceptably bright, resulting in discomfort. An acceptable compromise may be found by combining an uplighter installation with local task lighting, balancing adequate general illumination with localised brighter light for work.



Light Emitting Diodes (LEDs)

These are the most energy efficient and long-lasting light sources. You can buy a range of LED lamps, including dimmable LEDs, which are identifiable as such from the packaging.

It is worth remembering that in accommodation for older people, the population is likely to change from time to time and being able to change the lighting level is of considerable importance. A dimmer is a much cheaper solution than attempting to change lamps or luminaires.



- Tricolor LED lamp with tactile switches has a choice of colour temperatures and adjustable brightness



- Task lighting under a kitchen cupboard and above a hob highlights the full work surface.



- Natural overhead light enhances the contrasting finishes and colours; rounded furniture and well-defined doors make this an easy and safe reception to negotiate.



■ Good overhead use of daylight and high-level fittings cause minimum glare in this atrium.

Sensor lighting

Sensor lighting placed along routes such as corridors, particularly in accommodation for older people should pick up movement at a reasonable distance. This is to ensure that people are not entering a dark environment before the light eventually picks up their movement. To accommodate for older eyes and adaptation lighting should gradually increase rather than going from dark to full light in an instant.

Step changes

While a continuously variable system will enable lighting preferences to be met exactly, step changes can be

installed at a much lower price. For instance, a four-lamp fluorescent luminaire could be wired so that two lamps could be switched at a time, enabling the illumination to be doubled or halved, on demand. Taken a stage further, three switches would give a choice of one, two, three or four lamps. This system can also be applied to luminaires in a row, but here the disadvantage may be the unevenness that could result from switching off individual luminaires.

Task lighting

A person with sight loss may require high levels of illumination which are best achieved by placing the light



source close to the task. At the same time, he or she may also need to work near the task so that head, task and luminaire are extremely close together.

Not all task lighting solutions are achieved with adjustable reading lamps. In some situations – for example, hotel reception desks – it is usually done by spotlights mounted directly above the task. Again, this method has disadvantages for those who need to be close to the task, where they would cast a strong shadow. In such cases an adjustable reading lamp at the reception desk would do much to alleviate the problem.

Warm or cool lighting

Lighting can also help achieve the desired mood and ambience for an environment. The colour temperature of bulbs can range from warm to cold, the temperature of bulbs is measured in 'Kelvins. The higher up the Kelvin scale the 'colder' the bulb is which is 7,500 Kelvins at the higher end, and lower down the kelvin scale the warmer the light is which is 2,500 Kelvin's at the lower end.

Regardless whether a bulb is cold or warm, they must have good colour rendering factor. A poor colour render from a bulb can affect the true perception of the colour of objects

within an environment. Bulbs should have a Colour Render Index (CRI) between 80 and 100 to reflect the true colour of the objects it is illuminating.

Daylight

While daylight is the standard by which all other light sources are judged, it has both advantages and disadvantages. Even an overcast day can provide far more light than will be found in any artificial situation; and bright sunlight is measured in tens of thousands of lux. However, the rapid changes caused by passing clouds can bring problems of adaptation.

Indoors, daylight is usually the greatest source of glare. Elaborate methods are often adopted to reduce its effect; these can be films applied to the window glass to reduce visible and solar radiation, or tinted glazing and structural shielding methods. In the absence of these solutions, people resort to vertical or horizontal louvre blinds which bring problems of adjustment and maintenance.

Daylight supplements artificial electric light and of course advantage should be taken of this free light source. Even so, proper provision must be made to control daylight when it becomes more of a hindrance than a help.



On the following page, the Chartered Institution of Building Services Engineers (CIBSE) Code recommendations for task illuminance are set out. Observance

of the recommendations of the Code is usually 'deemed to satisfy' any mandatory requirements for the provision of lighting.

CIBSE Code for Lighting recommendations on task illuminance:

Location	Maintained illuminance* ** (lux)
Entrances halls, lobbies, waiting rooms	200
Enquiry desks	500
Circulation corridors, lifts, stairs	100
Lounges communal	100-300
Kitchens food preparation	150-300
Bedrooms	100
Offices general	500
Computer workstations	300-500
Filing rooms	300

* Maintained illuminance is the average value obtained immediately before maintenance is carried out, i.e. Before the luminaire is cleaned and the lamp cleaned or replaced.

** These lux levels should be modified in the light of the anticipated needs of those who are blind or partially sighted. This will often mean providing significantly more light – around twice for general circulation purposes – but much more for specific tasks.

At the same time, the option to dim high levels should be retained for the benefit of those who would find it a disadvantage.

Evaluating lighting proposals

This chapter has dealt with some of the key issues in the provision of better lighting to meet the needs of people with sight loss. The following checklist may assist when appraising lighting proposals:



- Glare should be avoided at all costs. Check the brightness of luminaires at all normal viewing angles and look for surfaces which might give glaring reflections.
- Areas should be lit to the levels recommended in the CIBSE Code with additional allowance made to cater for the needs of people with sight loss. Generally, the additional allowance should be 25 per cent to 50 per cent above the CIBSE recommendation.
- Light should be evenly distributed with no dramatic changes when moving from one area to another, for example from a work area to a corridor.
- Task lighting should be an essential part of the lighting system for people with sight loss, as well as an aid to everyone else. It is an economic way of raising the task illuminance without substantial increases in energy consumption.
- Where appropriate, the lighting level should be controlled by dimming or switching so that the illuminance can be adjusted to meet individual needs. This becomes especially important in residential accommodation.

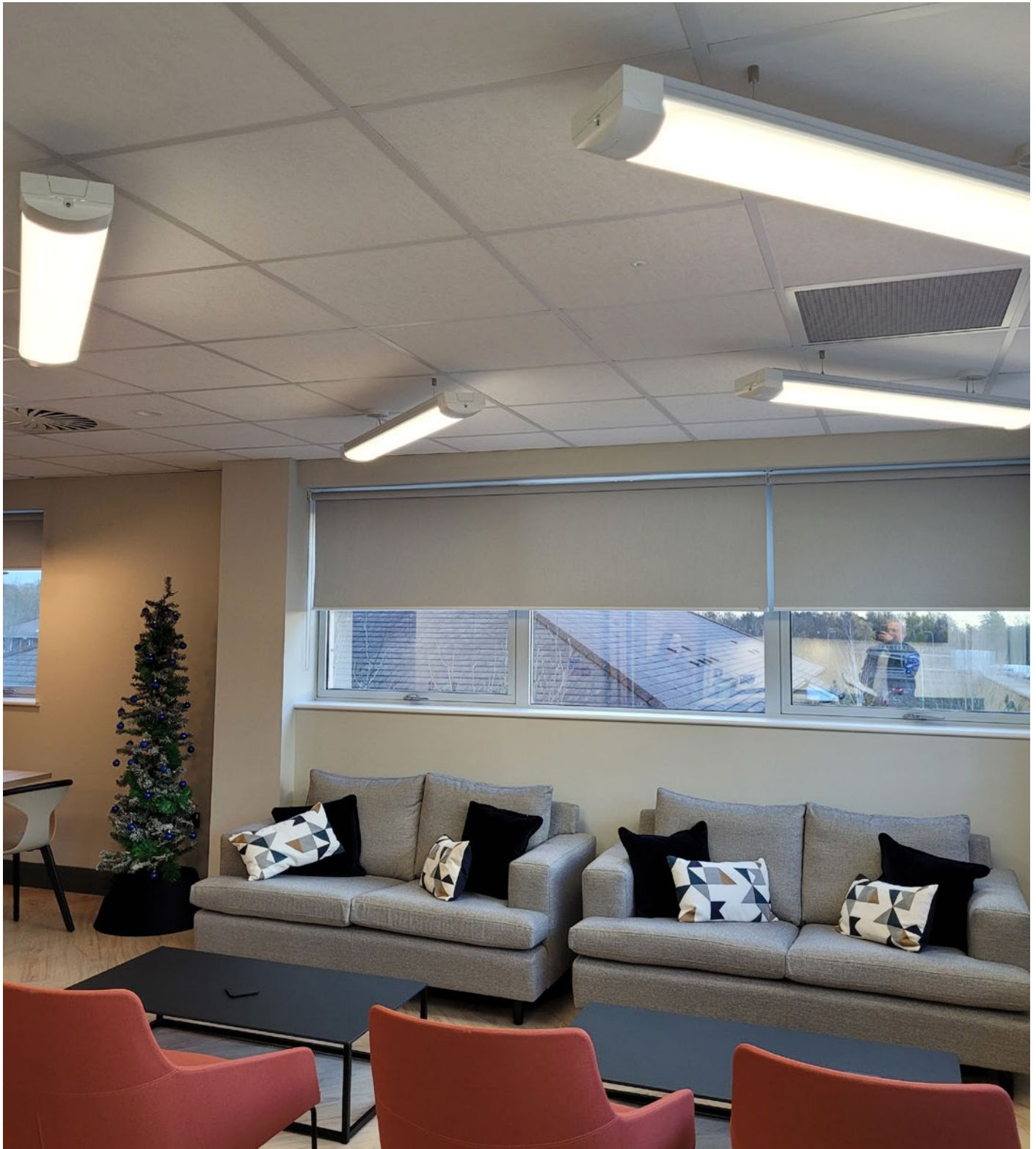

■ Image displays an even spread of light across the workplace communal area.



Interior Decoration





How interior spaces are decorated and finished can make an enormous contribution to quality of life for people with sight loss. A lot of the key themes – such as the need to create environments which are visually uncluttered and uncomplicated through the use of colours and contrast and to avoid optically difficult patterns for wall and floor finishes – have already been introduced earlier in this document.

The basic principles of interior decoration are:

- Walls should be finished in pale tones. All surfaces should be matt.
- Floorings should be plain without optically confusing patterns, and not gloss finished to produce glare or dazzle.
- The floor finish should contrast with the walls.
- Ceilings should be finished in pale colours to help reflect available light more evenly throughout the area.
- Doors should contrast with the surrounding walls so they can be easily identified. Door furniture should also contrast with the door.
- Items such as sockets, switches, pull cords, handles and so on, should be contrasted with their background so that they can be easily located.

- Soft furnishings should contrast with both walls and floors.

The introduction of simple patterns in a room should be carefully considered: greater variety should be balanced against the potential for visual confusion: for example, the challenge of finding keys or coins on a highly patterned bedspread.

This chapter develops some of the basic considerations with regard to interior decoration.

Visual contrast measures

The main feature of a surface, which appears to be strongly correlated with the ability of people with sight loss to identify differences in colour, is the amount of light the surface reflects, or its light reflectance value (LRV). The LRV scale runs from 0, which is a perfectly absorbing surface that could be assumed to be totally black, up to 100, which is a perfectly reflective surface that could be considered to be the perfect white. Because of practical influences in any application, black is always greater than 0 and white never equals 100.



The following table describes the required difference in LRV for two adjacent surfaces in order to make them apparent for people with sight loss:

Surface	Visual contrast value
Large area surfaces (i.e. walls, floors, doors, ceiling) and to facilitate orientation and guiding (i.e. handrails, door furniture, and visual indicators on glazed areas)	Difference in LRV \geq 30 points between the two surfaces
Potential hazards, (i.e. visual indicator on steps and glazed doors), small items (i.e. switches and controls) and self-contrasting markings	Difference in LRV \geq 60 points between the two surfaces or between the potential hazard and background surface
To facilitate reading of signs, information and instructions	Difference in LRV \geq 70 points between the text or symbols and the background

For reflecting materials (highly glossy or shiny surfaces used for one or both surfaces of interest, e.g. brushed metal) – a higher minimum luminance contrast value is required than for non-reflecting materials:

Surface	Visual contrast value
Large surface areas (i.e. walls, floors, doors, ceiling), elements and components to facilitate orientation (i.e. base plates of controls)	LRV difference \geq 40 points
Small items necessary to enable use of building elements (i.e. control buttons, inscriptions on controls)	LRV difference \geq 70 points



Wall finishes

Walls should be finished in plain, matt colours. A further step to create user-friendly interiors for people with sight loss would be to use generally pale colours for walls and ceilings. This not only maximises the available light, but also helps to distribute it evenly.

A soft sheen finish is satisfactory, but a matt finish is preferable where glare may cause problems. Rough finishes such as pebbledash should be avoided because some people with sight loss may wish to trail their hand along the wall in order to locate specific items. Trailing boards can be affixed along brick walls etc., to avoid hurt to trailing hands. Different tactile surfaces on walls can also be used strategically to aid orientation.

There is some scope to use small-patterned wallpapers in given areas. This can be useful to highlight chimney breasts or other features and to help make the area more aesthetically pleasing to sighted people.

For many people with sight loss, a small, patterned wallpaper can appear almost plain and therefore will not contribute significantly to environmental clutter and confusion. However, wallpapers with bold or large-scale patterns cause general visual confusion and may

make objects on shelves difficult to locate. Embossed wallpapers such as anaglypta, when finished with emulsion paint, are perfectly satisfactory, creating an interesting surface which is still user-friendly to people with poor sight.

Skirting boards and dado rails should be in a contrasting colour to the adjacent walls to provide additional help in navigating an area safely. These can be particularly useful for people left with only a small amount of side vision, offering valuable assistance in maintaining the line of travel along a corridor.

The use of floor-to-ceiling mirrors to create the illusion of space is a source of potential danger to people with sight loss, greatly distorting any realistic perception of space. Glass, too, can create problems, although here the problem is one of invisibility rather than reflection. Where areas are divided by plain glass screens or glass floor-to-ceiling partitions, the glass must be made visible with horizontal bands or some form of decorative motif at eye level (minimum 150mm height located within two zones, from 850mm to 1000 mm and from 1400mm to 1600mm from the floor, contrasting visually with the background seen through the glass in all light conditions. Patterned glass, though less problematic, should be treated in a similar fashion.



Floor patterns

Highly patterned carpets with a swirl or decorative tiles will create a great deal of visual confusion and could effectively 'hide' small articles inadvertently dropped onto the floor. Patterned floor coverings also alter the perceived shape of objects placed upon them, such as furniture, particularly where the colour of the object is fairly close to the hue of the carpet or floor covering. At worst, such patterns will make a person with sight loss feel apprehensive and uncomfortable in traversing a space. Also, they could result in people with poor sight colliding with chairs and settees.



■ The room as seen by someone with full vision



■ The same room as seen by someone with sight loss. This room demonstrates the importance of contrast between walls and floor, doors and furniture in negotiating a space.



■ Busy patterns cause confusion. A bunch of keys dropped on a light coloured small scale design is easier to find than on a large, dark design





Door details

In terms of decoration, doors should provide a good level of contrast with the walls and the floor where possible. The door should be clearly visible as a vertical rectangle finished in a different tone to the wall in which it is situated. This does not necessarily imply the use of garish colours – a dark grey door against a pale grey wall will provide a sufficient degree of contrast for most people. Remember that a dark red door situated in a dark green wall, whilst providing lively colour contrast, will offer very little in the way of tonal contrast.

Door furniture should also be clearly visible. It can be highly frustrating to someone with poor sight to have to search for a door handle. This problem is easily solved as modern products come in a wide range of finishes and colours.

A problem arises in very old or listed buildings where black wrought-iron door furniture may be mounted on a dark, oak-stained door. It is often not possible to paint the door furniture for historical and aesthetic reasons. A simple solution is to insert a small plastic sheet of a contrasting colour behind the door handle, using the existing door furniture fixtures to secure it. No permanent modifications have been made and the door is easily restored to its original appearance.

It is also useful to highlight the edges of doors, windows and so on in order to minimise the risk of collision if they are inadvertently left in a half-open position.

All doors should have soft closures or be hung on rising butt hinges to prevent them being left half open. Side doors and windows should not open into a corridor where a person with sight loss might collide with them.



- Doors, door furniture and switches should be contrasted with their backgrounds so that they can be easily identified



Where doors are numbered, the digits should contrast with the door surface in colour and / or tone and be raised 1.25 mm \pm 0.25 mm . Door numbers should be between 25 – 60mm in height and fitted at or just above average eye level (1.4 – 1.6m from the floor).

Signs mounted on doors should be designed in accordance with recommended practice: pale lower-case letters on a matt dark coloured background. Again, these should be situated at around eye level. A sign in braille may also be an appropriate option.

Soft furnishings

Although bold patterns should generally be avoided to minimise visual confusion, there is no doubt that under certain circumstances they can make objects more visible. One example might be a settee with a highly patterned fabric covering in a room with a carpet of plain or mottled style. In this instance, the settee will be highly visible, particularly if its background colour is tonally different from that of the carpet. (Even so a person with sight loss will still have difficulty in recovering items lost from the pocket when seated on the settee. That is why fabrics of a relatively plain or mottled style are generally preferred.)

Another positive use of patterns would be where they are deployed to give a focal point to an otherwise plain area – curtains, for example. As always, context is everything.



- Avoid heavily patterned soft furnishings such as bold curtains.



- Contrasting furnishings are the preferred option for people with sight loss.



■ Contrasting cushions on chairs are a good locator of where the seat is.



Signs and Notices





Key principles

Even in the best-planned environment, there will be a need for signs and notices. These basic principles should be adhered to when catering for the needs of people with sight loss:

- signs need to be simple, short and easily understood
- location of signs should be part of the process of planning the building and environment
- signs should be consistent, using prescribed typefaces, colours and other graphic devices
- signs and notices must inspire confidence through clarity.

For people with sight loss, the first problem is to locate the sign. Signs should be placed in a logical position and be obviously identifiable. The sign board must contrast with the background against which it is seen, and the lettering should contrast with the sign board. In the case of corporate signage where the sign board colour cannot be changed, a contrasting border should be put around the sign. The border width should be 10 per cent of the width of the sign.

The position of signs needs to be considered in the context of the overall design so that they do not constitute an obstruction and so that adequate illumination can be provided at all times. Signs are difficult to identify and read if they are positioned against a background of low-level sunlight or artificial light.

Legibility

- the legibility of signs is improved for people with a sight loss if, in general, white or light-coloured lettering is set on a dark background;
- sentence case (first letter only capitalised) lettering is generally easier to read;
- fixing the sign at eye level (between 1.4 and 1.6m above floor level) with easy access for close-up viewing is an advantage for all;
- to minimise glare, avoid reflective glass cases and ensure that the sign has a matt surface.

The following chart gives guidance on the colour contrast which should be used against some of the most used backgrounds for signs, such as brick, stone, whitewashed walls or green vegetation.



Schedule of colour contrast

Background	Sign board	Legend
Red brick or dark stone	White	Black, dark green or dark blue
Light brick or light stone	Black / dark	White / yellow
Whitewashed wall	Black / dark	White / yellow
Green vegetation	White	Black, dark green or dark blue

Tactile signs

Tactile signs are essential for people with no sight at all or those whose vision is only sufficient to locate a sign but not distinguish individual characters.

A tactile sign must be positioned where it can be easily touched, that means at a height of between 1.4m and 1.7m and at a forward distance of approximately half a metre. To be effective, a tactile sign must be embossed, not engraved.

The depth of embossing must be 1.25mm +/- 0.25mm and the stroke width 1.75mm. The edges should be slightly rounded – a half-round section is not acceptable. The minimum character height should be 15mm, the maximum 60mm. Some thought needs to be given to usage, for example, they are particularly important for toilet signage in order to allow for independent access to the correct facility.



- Visual and tactile toilet sign with maximum contrast



- Sign boards can be dangerous obstructions on the pavement



- Ideally, door signs should communicate clearly through visual, tactile and braille using upper and lower case letters



- Clearly signed exit door at waist level



- Pictogram based system for people with sight loss and students with learning difficulties

A tactile version of Helvetica bold sans serif is acceptable, giving an opportunity to combine a visible and tactile sign.

Braille

Braille is useful on appropriate signs. For single word signs, it is permissible to use grade 1 braille. For multi-word signs, contracted braille (Grade 2) must be used.

Some thought needs to be given to the positioning of braille signs. If they are low, the braille message will initially be 'upside down' to the reader's fingers, requiring the reader to crouch. Some braille signs are located on a 'braille bar' at a 30 degree angle from the horizontal, approximately 1m above the floor, enabling the user to stand and read.



A marker (e.g. a notch or tactile shape) should be located at the left-hand edge of the sign to help locate the braille message.

With any tactile / braille sign meant to be located by touch, it must be easy to locate by touch and well positioned, preferably allowing the reader to get close to it.



■ Visual and tactile sign above lift call button

High visibility and tactile signs should always be used on or adjacent to:

- toilet doors
- bathroom doors
- bedroom doors
- lift call buttons
- the top and bottom of flights of stairs
- wherever else it is necessary to show the function of a room.

Further information on tactile and braille signs, including their size and location, can be found in the Sign Design Guide.



■ A detail of the tactile sign board used to locate braille messages



Talking signs

Tactile signs should, where practicable, be complemented by audible information. These are widely available, triggered by remote control, and can be cheaply and easily installed. Wording must be informative and effective.

Symbols or pictograms

Where symbols or pictograms are used, they should be of a standard public information design, if one is available, or as simple and uncomplicated as possible if not. They should comply with the general provisions of signs in terms of colour contrasting, size, use of tactile embossed systems where appropriate, and so on.

Banding / border to assist with reading signs and notices

Loss of peripheral vision on one side, caused by damage to the optic pathways between the back of the eye and the visual cortex, has implications for reading signs and notices. If the loss is to the left, at the end of a written line, the difficulty will be getting back to the beginning of the next line. In most cases the eye will stop far short of the beginning of the line and recommence reading some way along it. The sentence will, of course, not make any sense so the person will

then spend time scanning around the page in order to locate where they have made the error.

To help with this instance, a bright coloured band down the left-hand side of a notice or a page may be helpful. This would help the person to locate the beginning of a line, making notices easier to read.

A further problem when scanning from the end of one line to the beginning of the next is that many people inadvertently slip two or three lines and therefore begin reading at a different place to the correct one. Sometimes this slippage is upwards to a previously read line, or downwards to a line which they have not yet come to. In some instances, the same line is read twice

If the loss in the visual field is on the right side (right hemi-anopia) most of the above problems will be eliminated. However, a new set of problems present themselves, as the word which is about to be read will be invisible until it pops up in the very central area of vision.

Furthermore, the end of the line may not be recognised. The technique of using a coloured band down the righthand side of the page would therefore be of assistance to people with this condition.



Whether the loss is to the right or the left, reading notices and signs is clearly going to be difficult and slow.

Height / location

Where it is likely that the sign may be obstructed, such as in a crowded situation, or for signs fixed to the ceiling

or projecting from walls, they should be at a height of at least 2 100 mm above the floor. This is in addition to wall-mounted signs between 1400 – 1700 mm from the floor surface. Care must be taken to ensure that signs are located so that people are able to stand and read the sign without impeding the pedestrian flow and possibly being bumped.



■ Toilet signage, contrasted sign at eye level with tactile images, words and braille.



Using Other Senses

Using other senses



When people move around within the built environment, they continually use a combination of senses to orientate themselves and to negotiate obstacles. When one of the senses is removed, or its effectiveness reduced, there is greater dependence on the others.

Sound

To a blind or partially sighted person, sound is a potentially helpful and positive source of information, but one that may sometimes cause confusion. A familiar auditory clue is the bleeper at a pelican crossing, which helps in two ways: first, it helps the blind pedestrian locate the crossing, and second, it indicates whether or not it is safe to cross.

Similar auditory clues or beacons could be provided in and around buildings to aid orientation and warn of hazards. Sound beacons could be installed at the entrance to a building to indicate to a person with sight loss that they have arrived at their destination. There could also be a spoken message to give the name of the building or occupier and some brief instructions on how to enter the building.

The common sounds within buildings also provide people with clues, and great care should be taken not to suppress or eliminate them totally.

Inside a shop, for example, the sound of a cash register will direct the visitor to a place where they are able to get assistance.

In a restaurant or café, the sound of preparation and serving of food might be helpful.

The rumbling noise from escalators, or the chimes that sound when lift doors open, help direct people to vertical circulation routes in a building. Fountains can aid wayfinding in landscaped surroundings.

Conversely, unnecessary noises which tend to swamp useful audible clues should be avoided. Background music played too loud in shops, public houses and restaurants can obliterate useful noises and result in disorientation and tension.

In office environments, the background noise level should be kept at around 55 db (maximum 70), whereas in factory regulations state the upper limit is 85 db. Designers will be well advised, therefore, to ensure that ambient noise level is kept to well below the statutory limits.

Those without any sensory disability may well become irritated by some of the auditory clues that help people with sight loss. Not everyone likes to hear a bleeper or a spoken message



continually broadcasting outside a building.

Various devices have now been developed which overcome this problem, ensuring that the message is transmitted only when there is a device, for example, a user's mobile phone, in the immediate vicinity. One of these is RNIB's React System, which consists of two elements: an app on a device carried by the user; and a receiver with an audible message. As the person approaches, the receiver is activated and broadcasts the appropriate message. This system has been used successfully in railway stations, shopping centres, and so on.

There are other electronic systems available which can be used as a means of calling for assistance or for direction finding. This is a rapidly developing area that designers might investigate in order to make provision for incorporating such devices into building design in due course.

Because many people with a sight loss are in the older age range, they may also have some sort of hearing impairment. In buildings where older people live or visit frequently, as many wayfinding clues as possible should be provided.

Induction loop systems to help the hard of hearing could be installed. The major cost with such systems is the amplifier, although this could be simply attached to wiring, if the wiring were to be built-in at the outset. Designers should be aware of the various factors that can adversely affect the performance of induction loops or infra-red systems. For example, high gloss floors and wall finishes can cause reflection of infra-red beams and seriously distort sound reproduction. The correct installation of such systems requires specialist knowledge.

People who are deafblind have a combination of impairments which create difficulties that exceed the sum of the individual impairments. There are design features that can assist. Organisations such as Sense, Deafblind UK and RNIB can offer help in this area.

Technology now exists for deafblind people to, for example, be made aware of visitors to their home via an app which activates a vibrating ring and flashing signal. Vibrating pads beneath pillows to indicate fire or other emergency. In addition to a growing market for voice-activated devices, such as the Amazon Echo.



Aromas

In some ancient cultures it was normal practice to impregnate mortar or similar bonding materials with herbs, which would differentiate one area of a building from another. Some timbers, such as cedars and redwood, give off distinctive fragrances which can also be used as wayfinding aids.

In outdoor areas, fragrant plants can improve the environment for all, and provide pleasure and orientation clues for people with sight loss. Plants produce fragrance from leaves and stems, as well as from flowers, and the tactile qualities of various plants can also be used for landmarking and wayfinding. The environment would benefit from a greater exploration of the properties of various plants as aromatic clue-givers.

One issue to bear in mind is to recognise that many species of plants have a limited season, so planning to provide an aromatic experience throughout the year will be necessary, by combining groupings of plants that can provide a continuity throughout the seasons.

Indoor places like laundries, washrooms, kitchens, coffee areas and so on can all be identified through aroma. It may be impractical to manipulate the position

of these activities on a site, but it is important to recognise that the clues they produce will aid orientation as people with sight loss make enhanced use of the sense of smell.

A number of commercial companies now produce machines, operated by battery or electrically from a mains supply that produce pleasant aromas. These have obvious usage in certain areas of buildings, like WCs, but could also be used as wayfinding clues if some thought is given to different aromas in different locations.

Other sensory input

The movement of air and the temperature of air currents are also important clues as to what is going on in an environment. Kinaesthetic information derived from the faculty which perceives voluntary motions of the body can be as important as sounds and aromas.

One blind person comments on air movements in a corridor:

“It gives you information about length and possibly the height. If you come through a swing door the waft of current from both sides would give you quite a clue to width and lengths.”



People with sight loss need to move around within the environment to establish detail, so designers should appreciate they will not only receive a variety of sensory information, they will actively seek it out in a process called 'mental mapping.'

Mental mapping is described by a blind person:

"It's the use of everything you could possibly use ... I store them up in a sort of pigeonhole mind. I know on every tube station I have ever been to which way to go out, from the change points to where to go to the gents. I do it by whether it's down a slope, or down three steps ... To the left or right, or something static like a kiosk."

Sterile environments devoid of sounds, smells and other sensory input are duller for everyone, but they make life much more difficult on a practical level for blind and partially sighted people.





- Sensory clues can support mind mapping when moving around an environment, for example the sound of a ticking clock.



Building Services





General

The design practicalities set out in previous chapters apply as much to building services as anything else. Equipment controls to which people require access should be logically planned and positioned, colour and tone contrasted, adequately illuminated and, where appropriate, include tactile symbols.

Door entry and exit systems

The door entry system, whether using a simple key, card or coded push-button, must be in an easy-to-find, accessible position. This is best achieved by positioning it on the latch side of the door at a height of between 900mm and 1100mm above floor level. The system should also be positioned close to the door frame rather than set back.

The lock or keypad should be colour – or tone-contrasted with the background against which it is seen. Depending on the hardware, this may need to be achieved by using a surround, border or backplate.

Door entry systems need to be adequately illuminated.

The operating method of some door entry systems is inherently complicated and user-unfriendly. For example, card systems requiring the card to be inserted from the bottom or at an oblique angle,

or where it is not clear which end of the card needs to be inserted first, have been known to make life difficult and stressful for disabled or elderly people. Such systems should be avoided where possible. A better system uses a key-fob which releases the door lock when the fob is in the proximity of the electronic reading mechanism.

In the case of keypad systems, the push-buttons should not be so small that they are difficult to operate by people with limited manual dexterity. The keys should not be so sensitive that they can be pressed in error. A good guide is an operating pressure of 3 Newtons, with a travel distance of approximately 2mm. The numbers should be clear and distinct and if a ten-figure keyboard is used the '5' should be highlighted with an embossed mark. Keypads should be laid out to resemble the telephone number layout, as many people with sight loss will be familiar with this.

In some cases, it is necessary to have an exit security system which can only be operated from inside the building. The traditional method has been to use a crash bar on fire door exits. However, electronic systems are now more frequently used. If these are operated by a press-button or pad, care should be taken again to ensure that the control is logically positioned, clearly visible and easy to find.



A useful system is to ensure that a large push-pad is used on the door frame and positioned at the end of a dado rail or handrail.

Lifts

Lift design decisions are usually made by multinational lift manufacturers, not interior designers or architects. However, it is our belief that sound advice should find its way back to decision makers at all levels and in all disciplines. Design professionals are therefore encouraged to advocate such recommendations to manufacturers and suppliers at every opportunity.

Lift cabins: General principles of contrast and tone apply here, but due to the usual lack of visual stimuli in lift cabins, it is advisable to provide additional assistance by using audible and tactile methods of information.

The position of controls inside and outside the lift is important, as they must be accessible to wheelchair users, people with restricted height, or small children.

The minimum internal dimensions should be 1.4m deep by 1.1m wide. This is the minimum size to give access to wheelchair users or to accommodate a person with a guide dog, sighted escort, pram, trolley, and so on. This size does not allow for larger wheelchairs and

there is insufficient space for wheelchair users to turn conveniently so a larger lift size is better.

The internal lighting should be of a medium level of intensity, ensuring an illuminance of at least 100 lux at the landing and on the control devices. The light should be as uniformly distributed as possible and the use of spotlights should be avoided.

The internal walls of the lift cabin should be covered with a non-reflective matt material preferably in a colour which contrasts with the colour of the floor (which should also have a matt finish). Highly reflective, or mirrored walls cause extreme visual confusion. In smaller lifts, of minimum dimensions 1400 x 1000mm, a mirror at the rear of the lift cabin may be required to assist wheelchair users. This mirror should not be the full height of the cabin but should be at least 1000 mm tall and have its bottom edge set at 600 mm above floor level. If the walls are decorated in any way, for example with advertising material, any glass or Perspex cover should be non-reflective.

A handrail along both sides and the back wall of a lift can be helpful to people who may need support. This should be positioned at a height of approximately 900 mm – 1000 mm above floor level.



The lift controls should be positioned at a maximum height above floor level of 1.4m. The bottom of the control panel should not be below 900mm. An optimum arrangement might be to have a control panel say, 200mm deep centred at 1100mm mm from the car floor. The control panel should be fitted on the left or right-hand side wall and at a distance of 400 mm minimum from the front wall of the lift. This improves access for people in wheelchairs. Control panels set close to the corner of a lift can be inaccessible.

The control buttons should be colour contrasted and with control buttons backlit and the legend on the button both visible and tactile (embossed, not engraved).

On any lift covering more than two floors, an audible indication of floor level should be used. Even on a lift travelling between only two floors, it is reassuring for a person with sight loss to have an audible announcement of floor level. Modern digitised speech systems are very flexible and the message can easily be changed.

The door opening time should be set to allow unhurried movement in and out of the lift for those with a mobility restriction.

Door closing should be controlled by photocell or proximity switches to prevent them closing against an obstruction.

Location: The lift should be easy to find; the colour of the lift doors should contrast with the wall finish in the vicinity. The lift call button will be more visible if it is mounted on the wall adjacent to the lift rather than in the lift door frame. The call button should be highlighted by the use of colour / tonal contrasting.

The floor level should be indicated on the wall adjacent to or just above the call button using both clear letters and a tactile form.

Escalators and travelators

Escalators: Although escalators provide a very convenient method of moving large numbers of people rapidly through a building, they can present a barrier if they are not carefully designed. In any event, there should always be a lift, stairs or ramp as an alternative for wheelchair users, those with a guide dog or anyone who, for whatever reason, does not wish to use an escalator.



The entry and exit to the escalator must be clearly visible and well illuminated. There should be a tactile warning (a distinct change in floor surface through texture and colour) at both the entry and exit from the escalator. The direction of movement of the escalator should be indicated by a red or green light.



- Confusion is caused by the lack of contrast, the shadows cast by the single overhead spotlight, no guide rail and the inaccessibility of the entry call buttons



- In this version, diffused lighting and maximum contrast help the user to locate the lift area



■ Lift exterior showing floor number and lift buttons



■ Controls inside lifts should be accessible to wheelchair users and have large, maximum contrast control buttons



■ 'Horizontal lift controls are more accessible for everyone'

Most people will enter an escalator on the right-hand side where it would be helpful to indicate with a high visibility and tactile sign whether the escalator is moving up or down. The side panels of the escalator channel should be finished in a non-reflective surface. Back illuminated side panels can be very disorientating. The moving handrail should extend beyond the entry and exit point by at least 150mm. The handrail should be colour and tone contrasted with its surround.

The area at the top and bottom of the escalator should be unrestricted and free from unnecessary obstructions such as portable pedestal-type signboards and display racks.

Although background noise is generally to be avoided, some noise from an escalator, particularly in a relatively open environment such as a railway station or shopping mall, provides a very useful clue to its location. It is useful if the surface of the escalator contrasts visually with the approach and if audible signals or pre-recorded messages indicate the start and finish of the escalator.



Travelators: Design requirements for travelators are naturally similar to those of escalators. A significant difference is that there is no warning of the imminent end of your journey by steps and handrail flattening out. On a travelator, an audible warning is needed at the start and finish, ensuring that there is good colour and tone contrast between the moving floor of the travelator and the fixed floor immediately at its end. Good lighting in the area should also be provided.

Valves and switches

Isolation valves, switches, fuse panels and so on, should be positioned so that they are easily accessible to people with sight loss and physical agility. It is unfortunately common practice in housing design to have the water stopcock fitted at a low level in a corner of the kitchen, in all probability inside a fitted cupboard. Similarly, the fuse box or reset buttons will be found high up on a wall where access can only be gained by use of steps or a ladder. In an emergency situation, this type of equipment needs to be accessed easily and quickly by any user. So it will benefit everyone, not only people with sight loss, to site them more sensibly.

Heating and air-conditioning controls

The main problem people with sight loss face in operating such controls is reading the instructions or scales on switches and control knobs. Setting programmers with times or thermostats with temperatures can be particularly problematical.

Many of these problems can be overcome by using equipment that has embossed tactile indicators and high visibility numbers or characters on scales.

This equipment should be positioned where it is accessible, clearly visible and well illuminated. If a control panel is surface mounted, care should be taken to ensure that an unsuspecting person walking close to the wall will not bump into it.

It is important that radiators and hot water pipes are not placed adjacent to the WC or any other area where there is a danger of being burnt. Low surface-temperature radiators are an option, but these too must be carefully sited.



Emergency call systems

It is often appropriate to have an emergency call system in a toilet, bathroom or kitchen. A continuous cord stretching from ceiling to just above floor level should be used. The cord should be fairly thick – so that it is easy to grip. It may be helpful to provide two bangles, one just above floor level (100 mm) and another attached between 800 mm – 1000 mm above floor level. The cord and bangle should be red to contrast with the background against which they are seen and as it is traditionally associated with emergency systems.

In a facility that is going to be used by many people with sight loss, it is a good idea to provide an audible clue to the location of the pull cord such as small bells or rods that ring and chime with minimal touch or movement. These are a constant reminder of the position of the emergency pull cord.

If an emergency button is used, it should be well positioned, clearly visible and have a pressing area large enough to be operated by a person with restricted manual dexterity. The button should feel positive and it should be surrounded by a raised bezel to prevent accidental operation. An operating force of around 3 Newtons with a movement of approximately 2mm is recommended.

For deafblind people, a personal vibrating pager and visual alarm systems can give indication of a ringing doorbell, a ringing telephone, or the fire alarm by different patterns of vibration.



- The cord should be fairly thick and be red to contrast with the background.

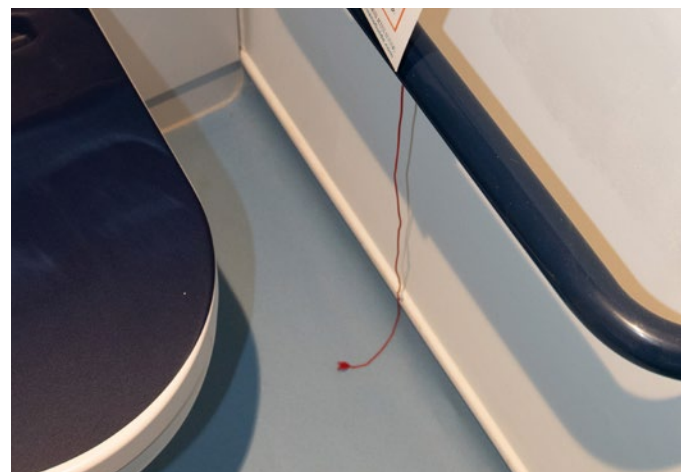

- The cord should be fairly thick and be red to contrast with the background.





Building Management





Maintenance and renovation

After a period of a few years, any building will require redecoration, refurnishing, perhaps some additional fittings, maybe even complete renovation. The building designers originally involved will have moved on and those now responsible may not be aware of the thinking behind many of the original installations and provisions.

The temptation to create a fresh look runs the risk of undoing a lot of good work: for example, the re-carpeting of a staircase might involve forgetting the nosing.

It is important, therefore, that there should be permanent records of the specification of the internal finishing of the building, together with some explanatory notes. An inclusive design strategy which follows through all design stages from concept brief through to in-use and occupancy.

Commercial buildings should set up regular inspection routines to ensure that all aspects of a building are kept to a good standard of repair. This approach can help prevent accidents and major repair bills whilst enabling expenditure to be planned and controlled as part of the overall management accounts.

Where sometimes hard-won improvements for disabled people have been incorporated, it is essential that standards are maintained and not allowed progressively to decline through indifference or insensitivity.

Organisational culture

Inevitably, the question of organisational culture arises. Encouraging proper attitudes is as important as installing appropriate equipment. Often building managers cannot rely solely on the provision of good facilities and effective maintenance. It may be necessary to train staff to notice whether people using the building, experience any barriers, obstacles and challenges and identify any additional assistance that might be needed.

Consider the actual example of a prestigious hotel which has excellent fire precautions and emergency procedures. Behind its reception desk a sign with large lettering says, 'If you are likely to require assistance in the event of an emergency, please advise the receptionist when you check in'. This is of no use to a person with sight loss and unless staff are trained to identify the indicators of sight loss and give a verbal explanation, some of their most susceptible guests are disadvantaged.



Similarly, a receptionist giving directional instructions should be made aware that using phrases such as 'over there', 'in that direction', or simply pointing, is of little help to a person with sight loss.

Good housekeeping

Housekeeping affects the appearance, efficiency and safety of any building. Systems and procedures should be established from the outset to ensure good practice. Here are a few suggestions:

- boxes should not be left in entrances and corridors;
- fire escapes must never be blocked;
- doors must not be propped open with waste bins;
- fire extinguishers should be checked on a regular planned basis;
- filing cabinet drawers must not be routinely left open;
- dirty or unrepaired light fittings and windows will cancel the designer's best lighting decisions.

It is not within the scope of this book to recommend how good building maintenance and housekeeping might be achieved. However, we raise these issues simply because it is important to stress that good building design does not stop with prescription – to be successful it must be sustained in use.





■ A cluttered toilet area used for storage is bad practice.



Dedication

This publication is dedicated to the memory of Peter Barker OBE

Peter was our manager when we worked at JMU Access Partnership, a unit – jointly funded by RNIB and Guide Dogs – he set up to inspire architects, designers and others to embrace inclusive design and meet the needs of people with sight loss.

Peter was not only our manager, he was our mentor, our inspiration and our friend. We are honoured RNIB asked us to update this publication, which Peter, with his then RNIB colleagues Jon Barrick and Rod Wilson, wrote in 1995.

Building Sight was the first publication to set out the design principles and practical recommendations to create environments that meet the requirements of people with sight loss and integrate these within the philosophy and practice of inclusive design. More than 25 years later it remains essential reading for those responsible for designing and managing our built environment.

In this update we have sought to retain the essence of the original publication as well as updating it to meet the needs of the 21st Century.

Carol Thomas MBE and Caroline Lewis

RNIB Helpline



Call: **0303 123 9999**



Email: **helpline@rnib.org.uk**



Or say, **"Alexa, call RNIB Helpline"**
to an Alexa enabled device.

rnib.org.uk